

ALL DESIGN, OPERATIVE AND PROCESS DATA PERTAINING TO THE ARTICLE SHOWN ON THIS SHEET IS THE PROPERTY OF POLYPHASER CORPORATION. THE INFORMATION IS NOT TO BE COPIED, REPRODUCED, REVEALED TO OR APPROPRIATED BY OTHERS WITHOUT THE EXPRESS WRITTEN CONSENT OF POLYPHASER CORPORATION.

These commodities or technology are exported from the U.S. in accordance with the Export Administration Regulations. Diversion contrary to U.S. law prohibited.

REVISIONS				
REV LTR	DATE	ENG	MKTG	Q.A.
D	9/10/13 RC	-	- -	- -

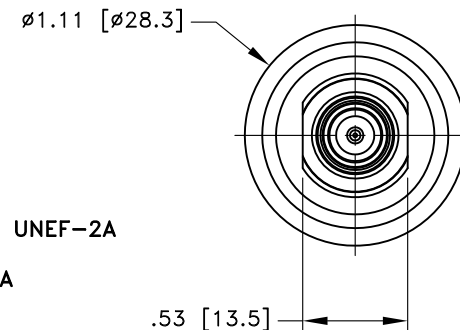
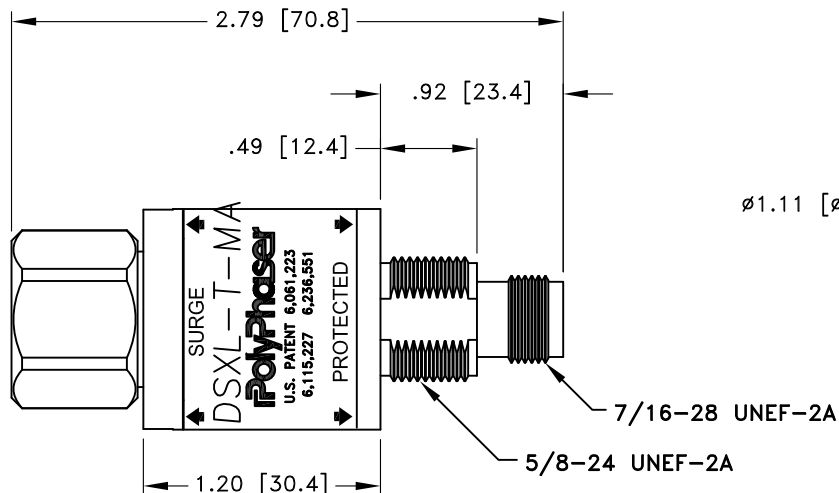
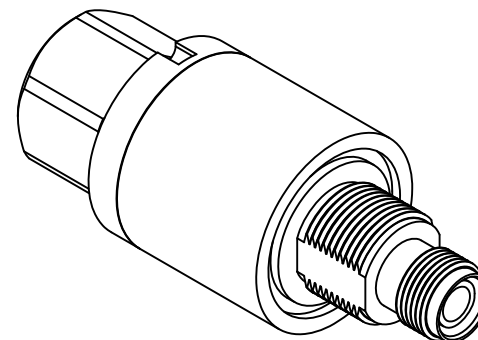
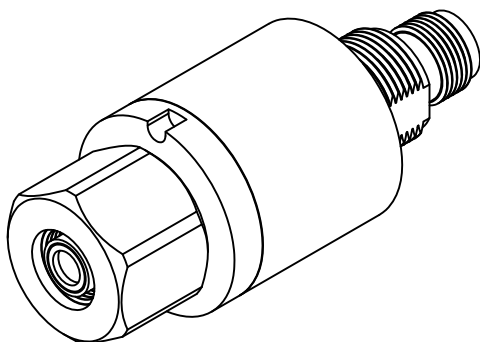

MAXIMUM CHARACTERISTICS

APPLICATION:
BULKHEAD MOUNT
WEATHERPROOF WHEN INSTALLED
 SURGE:
 18kA IEC 61000-4-5 8/20μs WAVEFORM
 FREQUENCY RANGE:
 800MHz TO 2.0GHz
 (700MHz TO 2.5 GHz @ 1.25:1 VSWR)
 VSWR:
 ≤1.1:1 TYPICAL
 INSERTION LOSS:
 <0.1dB
 CONTINUOUS POWER:
 500W@920MHz
 (750W @ 50°C)
 LET THROUGH VOLTAGE:
 ≤±3 VOLTS FOR 3kA @ 8/20μs WAVEFORM
 THROUGHPUT ENERGY:
 <0.5μJ FOR 3kA @ 8/20μs WAVEFORM
 TEMPERATURE:
 -40°C TO +85°C STORAGE/OPERATING
 VIBRATION:
 1G AT 5Hz TO 100Hz
 ENVIRONMENTAL:
 MEETS IEC 60529 IP67 Ⓟ
 MEETS BELLCORE #TA-NWT-000487
 PROCEDURE 4.11, WIND DRIVEN (120MPH)
 RAIN INTRUSION TEST.

CUSTOMER APPROVAL: _____ DATE: _____
 ALL DIMENSIONS SHOWN ABOVE ARE FOR REFERENCE ONLY.

DRAFTER R. SWART	DATE 10/07/04
MECH ENGINEER R. DUNNING	DATE 10/08/04
ELEC ENGINEER J. JONES	DATE 10/08/04
MARKETING S. DOTTER	DATE 10/11/04
QUALITY DEPT L. JACQUES	DATE 10/11/04

PolyPhaser

P.O. BOX 9000 MINDEN, NV 89423 TEL: 775-782-2511 FAX: 775-782-4476
 DWG NO/PART NO/DESCRIPTION

DSXL-T-MA
 CUSTOMER PRINT

CAGE CODE	FILE NAME	SCALE	SHEET
61114	DSXL-T-MA-C1	1/1	1 OF 1