

# TD-850B-LTE78-43 | E14Z00P06

---

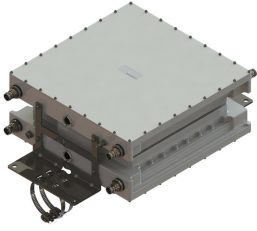

## Twin In-band Diplexer 850 MHz, DC Sense

- Enables LTE carrier to share the RF path with other CDMA/EVDO services
- LTE port supports the use of dual band 700/850 radios or diplexed radio ports
- CDMA port supports carriers F1(384), F2(425), F3(466) and F8(770/777)
- Optimized for 5MHz LTE carrier on B-Block CH 2585 and 10MHz LTE carrier on A-Block CH 2460
- Narrow guard band to maximize utilization of licensed spectrum

## Product Classification

**Product Type** Diplexer

## General Specifications

**Application** Indoor | Outdoor

**Antenna Interface** 4.3-10 Female

**Connector Interface Style** Long neck

## Dimensions

**Height** 392 mm | 15.433 in

**Width** 387 mm | 15.236 in

**Depth** 162 mm | 6.378 in

**Ground Screw Diameter** 6 mm | 0.236 in

## Outline Drawing

# TD-850B-LTE78-43 | E14Z00P06

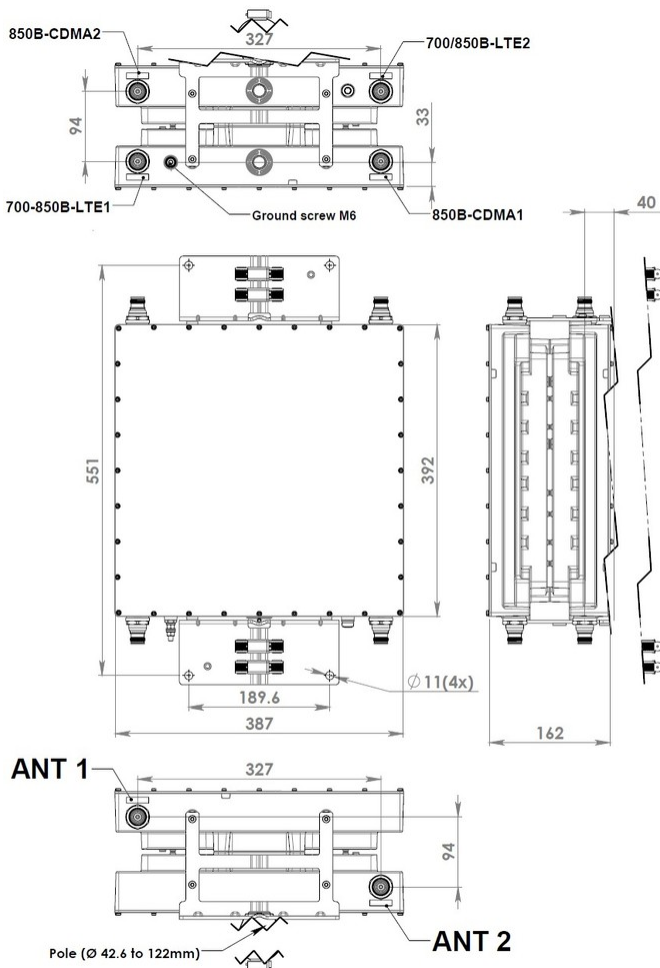

## Electrical Specifications

<b>5th Order IMD Test Method</b>	Two +43 dBm carriers
<b>5th Order IMD, maximum</b>	-161 dBc
<b>Lightning Surge Current</b>	10 kA
<b>Lightning Surge Current Waveform</b>	8/20 waveform

## Electrical Specifications, Rx (Uplink)

<b>Frequency Band</b>	777 – 787 MHz   825.5 – 834.5 MHz   840.25 - 844.75 MHz
<b>Return Loss, minimum</b>	18 dB
<b>Isolation, minimum</b>	28 dB
<b>Port Designation</b>	700/850 LTE
<b>Total Group Delay, maximum</b>	320 ns

# TD-850B-LTE78-43 | E14Z00P06

## Electrical Specifications 2, Rx (Uplink)

<b>Frequency Band</b>	835.905 – 839.595 MHz   847.485 - 848.925 MHz
<b>Isolation, minimum</b>	28 dB
<b>Port Designation</b>	850B CDMA
<b>Total Group Delay, maximum</b>	320 ns
<b>Return Loss, minimum</b>	18 dB

## Electrical Specifications, Tx (Downlink)

<b>Frequency Band</b>	746 – 756 MHz   870.5 – 879.75 MHz   885.25 - 889.75 MHz
<b>Isolation, minimum</b>	28 dB
<b>Input Power, PEP, maximum</b>	1500 W
<b>Input Power, RMS, maximum</b>	120 W
<b>Total Group Delay, maximum</b>	320 ns
<b>Return Loss, minimum</b>	18 dB

## Electrical Specifications 2, Tx (Downlink)

<b>Frequency Band</b>	880.905 – 884.595 MHz   892.485 - 893.925 MHz
<b>Input Power, PEP, maximum</b>	1500 W
<b>Input Power, RMS, maximum</b>	120 W
<b>Isolation, minimum</b>	28 dB
<b>Return Loss, minimum</b>	18 dB
<b>Total Group Delay, maximum</b>	320 ns

## Electrical Performance

### Insertion Loss Specifications

850B-CDMA TO ANTENNA PORT		700/850AB-LTE TO ANTENNA PORT	
Channels	Specification (dB)	Channels	Specification (dB)
384, 425, 770, 777*	1.2 max	700 LTE	0.15 max
466*	1.5 max	850 LTE 2585, 2460*	0.9 max

\* Specifications are for the average of the freq. band

### Frequency Map

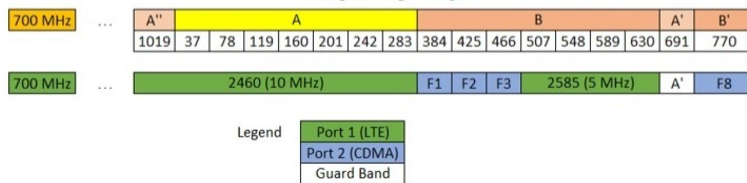

## Block Diagram

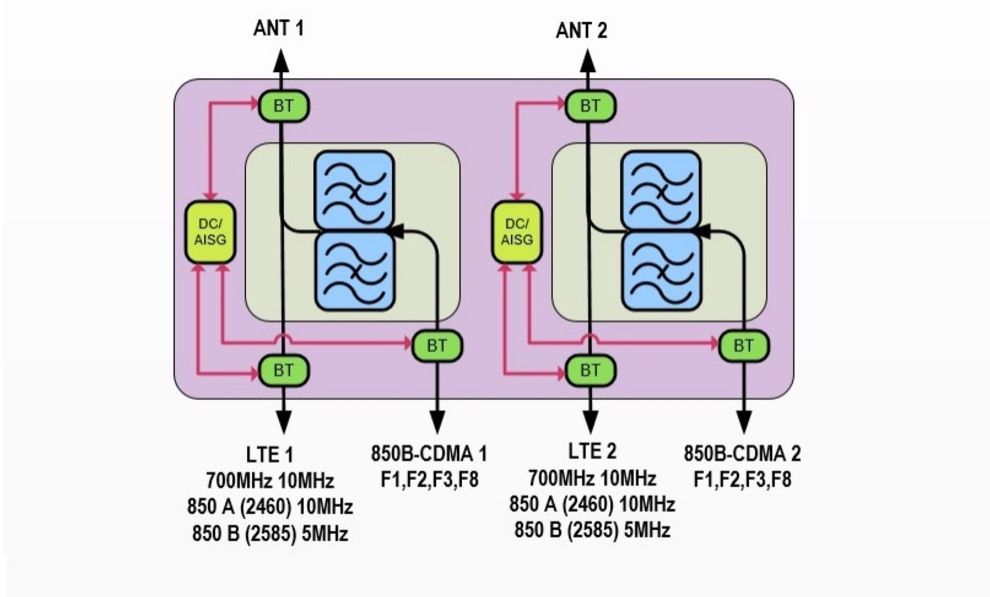

## Logic Table

DC input voltage		ANT Port
LTE Port	CDMA Port	DC/AISG path selection
<7	<7	All Ports OFF
$7 \leq V \leq 30$	<7	<b>LTE Port to ANT Port ON</b> CDMA Port to ANT OFF
<7	$7 \leq V \leq 30$	LTE Port to ANT Port OFF <b>CDMA Port to ANT ON</b>
$7 \leq V \leq 30$	$7 \leq V \leq 30$	All Ports OFF

## Environmental Specifications

**Operating Temperature** -40 °C to +65 °C (-40 °F to +149 °F)

**Ingress Protection Test Method** IEC 60529:2001, IP67

## Packaging and Weights

**Included** Brackets

**Weight, net** 24 kg | 52.911 lb