

L2TDM-PL



7-16 DIN Male Positive Lock for 3/8 in LDF2-50 cable

Product Classification

Product Type	Wireless and radiating connector
Product Brand	HELIAX®
Product Series	LDF2-50

General Specifications

Body Style	Straight
Cable Family	LDF2-50
Inner Contact Attachment Method	Captivated
Inner Contact Plating	Silver
Interface	7-16 DIN Male
Mounting Angle	Straight
Outer Contact Attachment Method	Ring-flare
Outer Contact Plating	Trimetal
Pressurizable	No

Dimensions

Height	34.54 mm 1.36 in
Width	34.54 mm 1.36 in
Length	51.31 mm 2.02 in
Diameter	34.54 mm 1.36 in
Nominal Size	3/8 in

Outline Drawing

L2TDM-PL

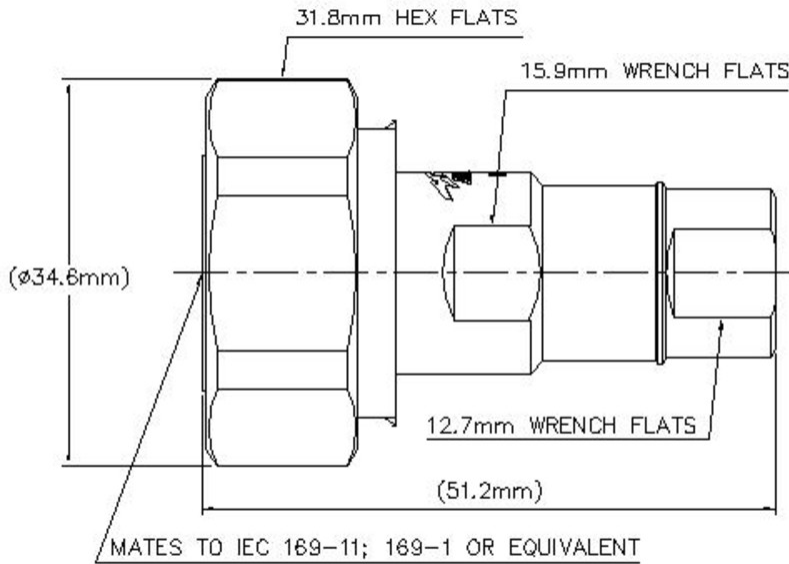

Electrical Specifications

3rd Order IMD at Frequency	-107 dBm @ 910 MHz
3rd Order IMD Test Method	Two +43 dBm carriers
Insertion Loss Coefficient, typical	0.05
Average Power at Frequency	0.7 kW @ 900 MHz
Cable Impedance	50 ohm
Connector Impedance	50 ohm
dc Test Voltage	2500 V
Inner Contact Resistance, maximum	0.4 mOhm
Insulation Resistance, minimum	10000 MOhm
Operating Frequency Band	0 – 10000 MHz
Outer Contact Resistance, maximum	1.5 mOhm
Peak Power, maximum	15.6 kW
RF Operating Voltage, maximum (vrms)	894 V
Shielding Effectiveness	-110 dB

VSWR/Return Loss

Frequency Band	VSWR	Return Loss (dB)
0-960 MHz	1.027	37.51

L2TDM-PL

960–2200 MHz	1.058	31
2200–2700 MHz	1.065	30.04
2700–4000 MHz	1.083	27.99
4000–6000 MHz	1.089	27.41
6000–8000 MHz	1.089	27.41
8000–10000 MHz	1.36	16.5

Mechanical Specifications

Attachment Durability	25 cycles
Connector Retention Tensile Force	671.68 N 151 lbf
Connector Retention Torque	2.7 N-m 23.897 in lb
Coupling Nut Proof Torque	35 N-m 309.776 in lb
Coupling Nut Retention Force	1000 N 224.81 lbf
Coupling Nut Retention Force Method	MIL-C-39012C-3.25, 4.6.22
Insertion Force	199.99 N 44.96 lbf
Insertion Force Method	IEC 61169-1:15.2.4
Interface Durability	500 cycles
Interface Durability Method	IEC 61169-4:17
Mechanical Shock Test Method	IEC 60068-2-27

Environmental Specifications

Operating Temperature	-55 °C to +85 °C (-67 °F to +185 °F)
Storage Temperature	-65 °C to +125 °C (-85 °F to +257 °F)
Attenuation, Ambient Temperature	20 °C 68 °F
Average Power, Ambient Temperature	40 °C 104 °F
Average Power, Inner Conductor Temperature	100 °C 212 °F
Corrosion Test Method	IEC 60068-2-11
Immersion Depth	1 m
Immersion Test Mating	Mated
Immersion Test Method	IEC 60529:2001, IP68
Moisture Resistance Test Method	IEC 60068-2-3
Thermal Shock Test Method	IEC 60068-2-14
Vibration Test Method	IEC 60068-2-6

L2TDM-PL

Packaging and Weights

Weight, net 102.12 g | 0.225 lb

Regulatory Compliance/Certifications

Agency	Classification
ISO 9001:2015	Designed, manufactured and/or distributed under this quality management system

* Footnotes

Insertion Loss Coefficient, typical 0.05√freq (GHz) (not applicable for elliptical waveguide)

Immersion Depth Immersion at specified depth for 24 hours