

4

3

2

1

NOTES:

- 1.0 PUT ALL LOOSE HARDWARE IN POLYBAGS AS NEEDED.
- 2.0 PLACE DRAWING INTO CRATE.

REVISIONS				
REV	ECN	DESCRIPTION	BY	DATE
A	8000011948	INITIAL RELEASE	DRR	01/07/16

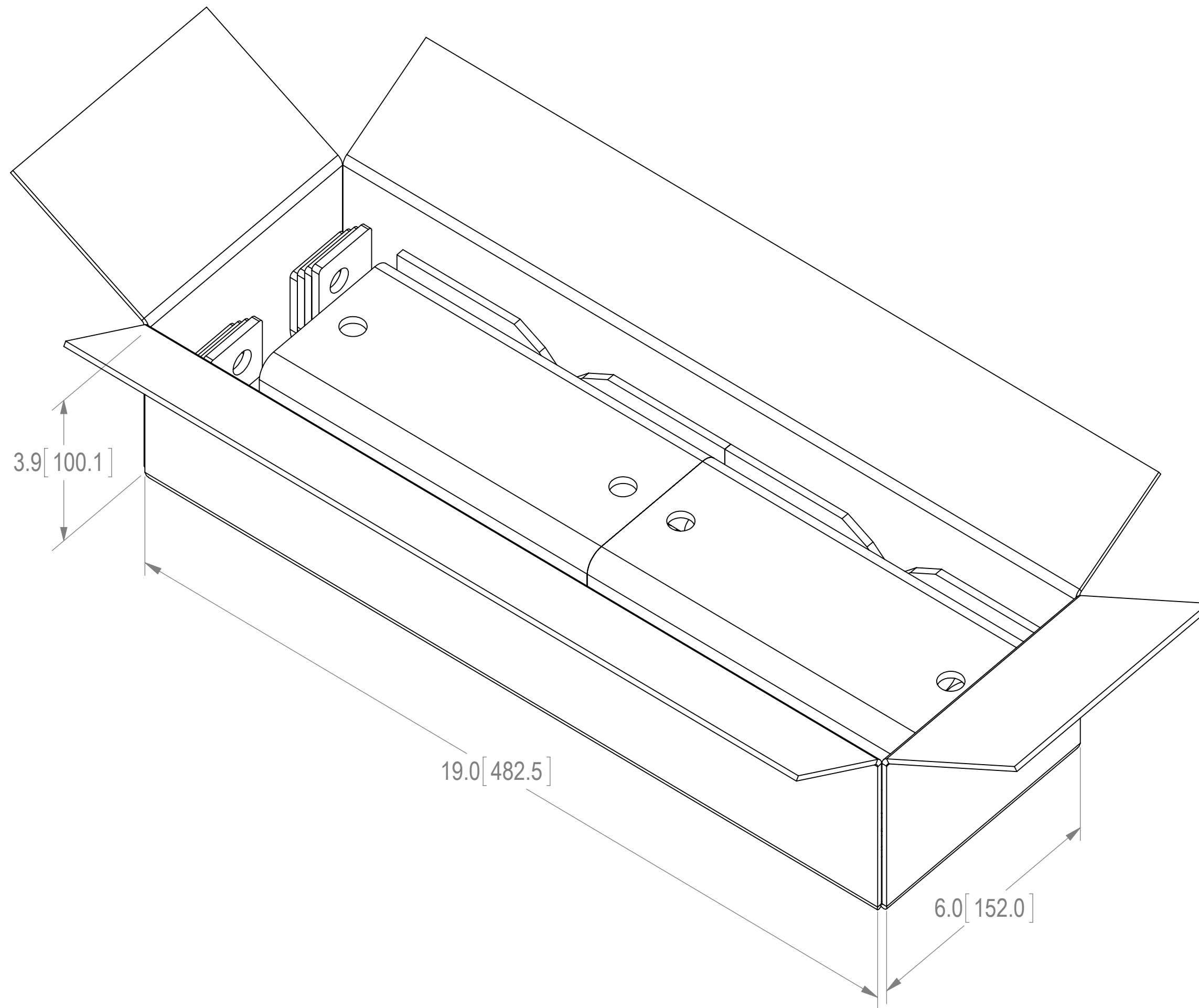

ITEM	PART NO.	DESCRIPTION	QTY.	WEIGHT	NOTE NO.
1	MTC378912	WELDED FRONT BRACKET	2	4.18 LBS	
2	MTC378909	RRU HANGER	4	3.97 LBS	
3	MTC378903	REAR BRACKET	2	3.10 LBS	
4	MT-379	1/2" X 12" GALV THREADED ROD	4	0.66 LBS	
5	MTC3789HK	HARDWARE KIT FOR MTC3789	1	2.44 LBS	
6	BX22	Box Kraft 19" x 6" x 4"	1	-	
7	DOCUMENT RECORD	INSERT DWG RR-FA2 INTO BOX	1	-	1,2

COMMSCOPE, INC. OF NORTH CAROLINA									
TOLERANCES					SAP MATERIAL MASTER				
0 PLACE X ± .25		2 PLACE .XX ± .06			RR-FA2				
1 PLACE .X ± .12		ANGLES ± 2°							
FINISH					MATERIAL				
GALV A123					A36				
UNLESS OTHERWISE SPECIFIED DIMENSIONS ARE IN MILLIMETERS INTERPRET PER ISO STANDARDS HANDBOOK TECHNICAL DRAWINGS VOLUMES 1 & 2, THIRD EDITION (2002)	CE	NAME	DATE	TITLE					
	RW	ADW	9/10/15	RRU MOUNT					
	RV								
	AD								
	RE	TP	9/10/15	SCALE	DOCUMENT NO.				
ECN	8000011948			1:2	RR-FA2				
SIZE	WORK AREA		MODEL			DRAWING			
C			VERSION	STATUS	REVISION	VERSION	STATUS	REVISION	SHEET
								A	1 OF 5

DENSITY	0.19	lbs/in ³
MASS	35.88	lbs
VOLUME	184.00	in ³
SURFACE AREA		in ²
HEIGHT		
LENGTH		
WIDTH		

PATENT PENDING
 © 2015 CommScope, Inc. Confidential

4

3

2

1

NOTES:

- 1.0 ALL METRIC DIMENSIONS ARE IN BRACKETS.
- 2.0 MOUNT WILL FIT LEGS UP TO:
 - Ø 5.6" ROUND
 - 6.0" 60° ANGLE
 - 4.5" 90° ANGLE

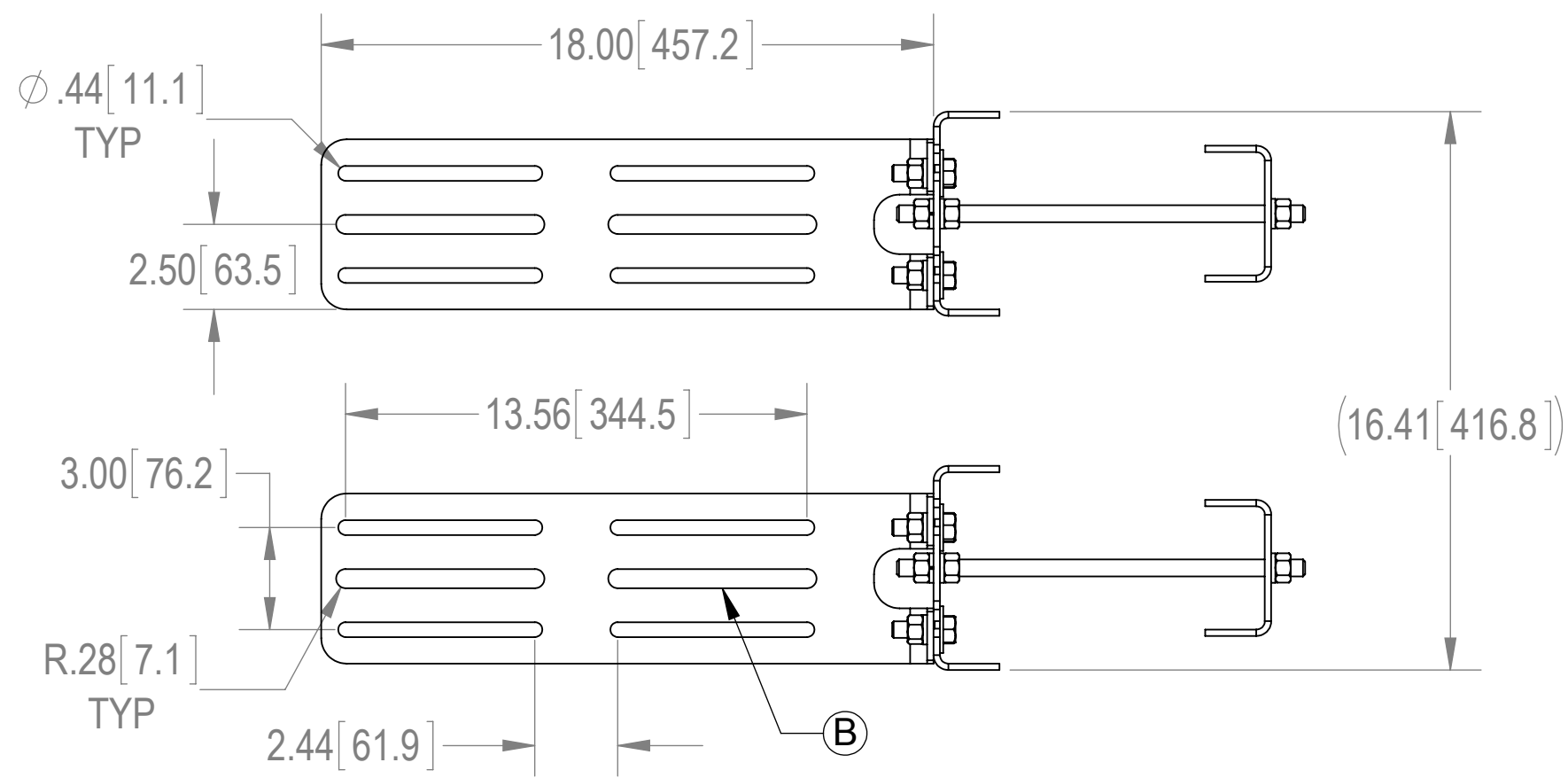
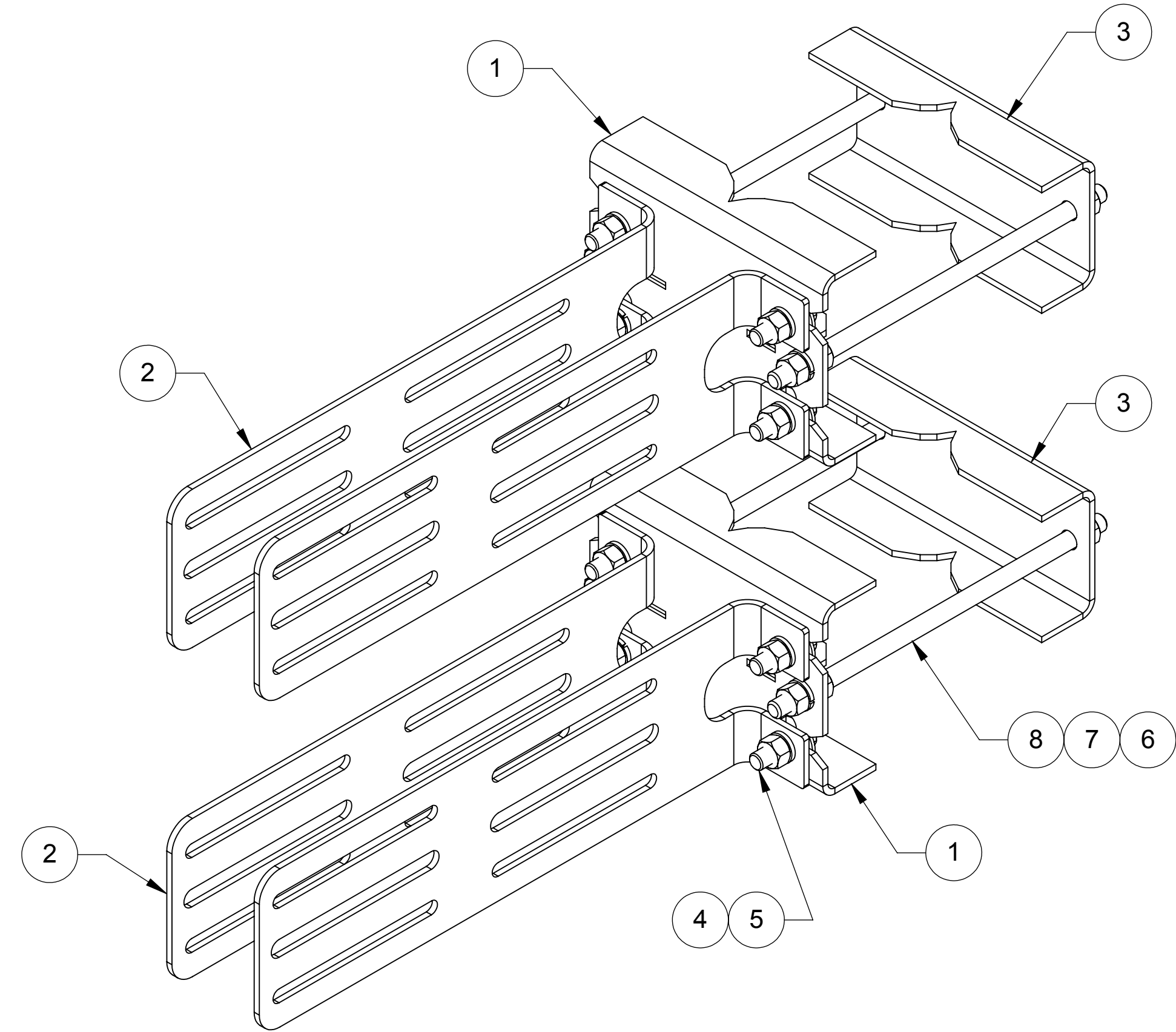
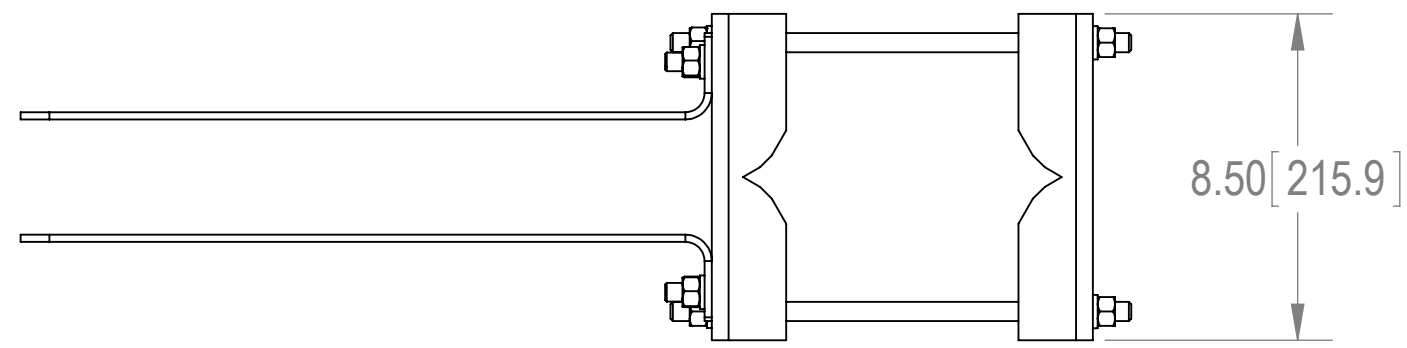

ITEM	PART NO.	DESCRIPTION	QTY.	WEIGHT	NOTE NO.
1	MTC378912	WELDED FRONT BRACKET	2	4.18 LBS	
2	MTC378909	RRU HANGER	4	3.97 LBS	
3	MTC378903	REAR BRACKET	2	3.10 LBS	
4	GWF-04	1/2" GALV FLAT WASHER	8	0.03 LBS	
5	GB-04145	1/2" X 1-1/2" GALV BOLT KIT	8	0.13 LBS	
6	GWL-04	1/2" GALV LOCK WASHER	12	0.01 LBS	
7	GN-04	1/2" GALV HEX NUT	12	0.04 LBS	
8	MT-379	1/2" X 12" GALV THREADED ROD	4	0.66 LBS	

COMMSCOPE, INC. OF NORTH CAROLINA			
TITLE			
FAST ACCESS DUAL RRU MOUNT			
SIZE	SCALE	DOCUMENT NO.	
C	1:3	RR-FA2	
DRAWING			SHEET
VERSION	STATUS	REVISION	2 OF 5
		A	

PATENT PENDING
 © 2015 CommScope, Inc. Confidential

4

3

2

1

NOTES:

- 1.0 PRE-ASSEMBLE HANGER BRACKETS & RRUS
- 2.0 WITH ITEMS 4&5 LOOSE, SLIDE HANGER INTO POSITION THEN TIGHTEN BOLTS FOR INSTALLATION

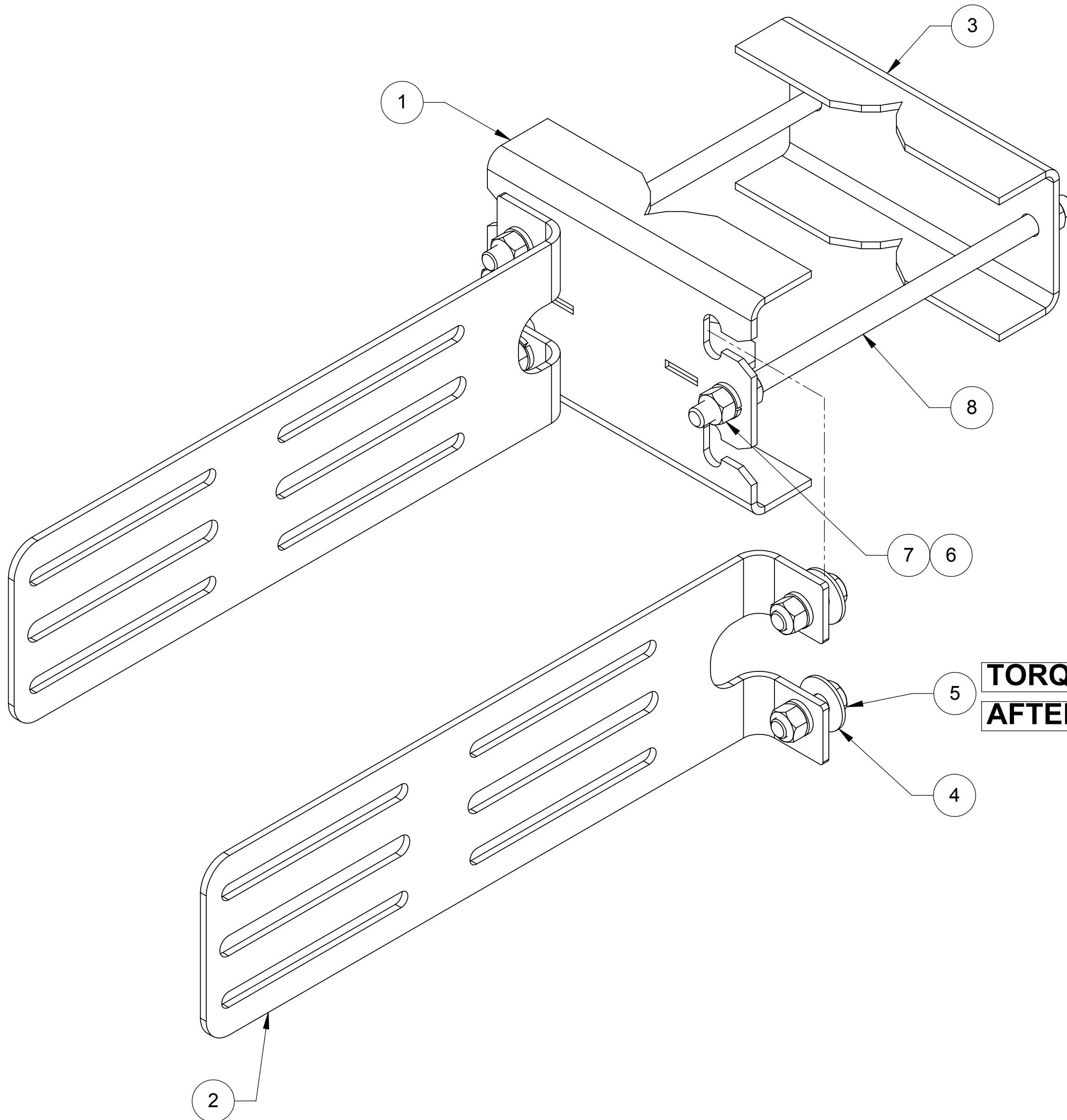

**TORQUE BOLTS TO 60ft lbs
AFTER INSTALLATION**

COMMSCOPE, INC. OF NORTH CAROLINA				
TITLE				
FAST ACCESS DUAL RRU MOUNT				
SIZE	SCALE	DOCUMENT NO.		
C	1:2	RR-FA2		
		DRAWING		SHEET
		VERSION	STATUS	REVISION
				A
				3 OF 5

PATENT PENDING
© 2015 CommScope, Inc. Confidential

4

3

2

1

4

3

2

1

NOTES:

1.0 EXAMPLE INSTALLATION WITH RRU'S.

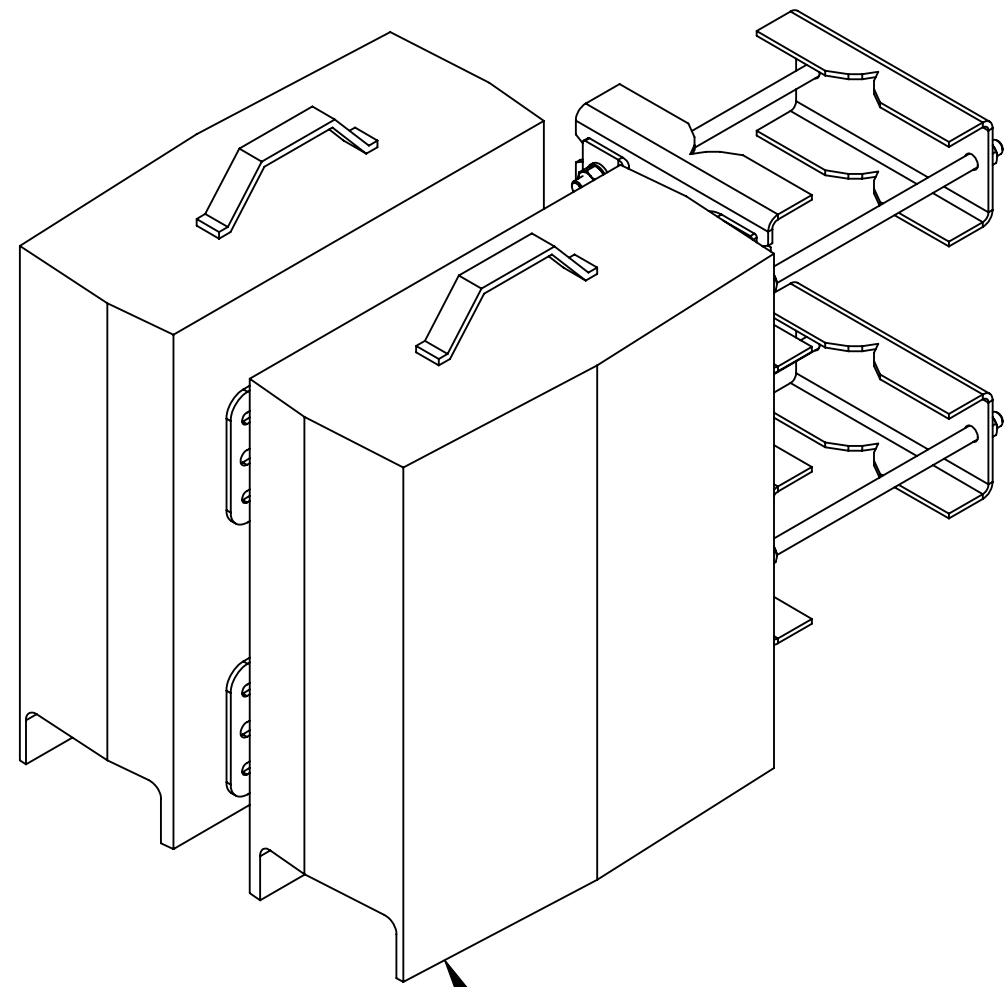

RRU ORDERED SEPARATELY

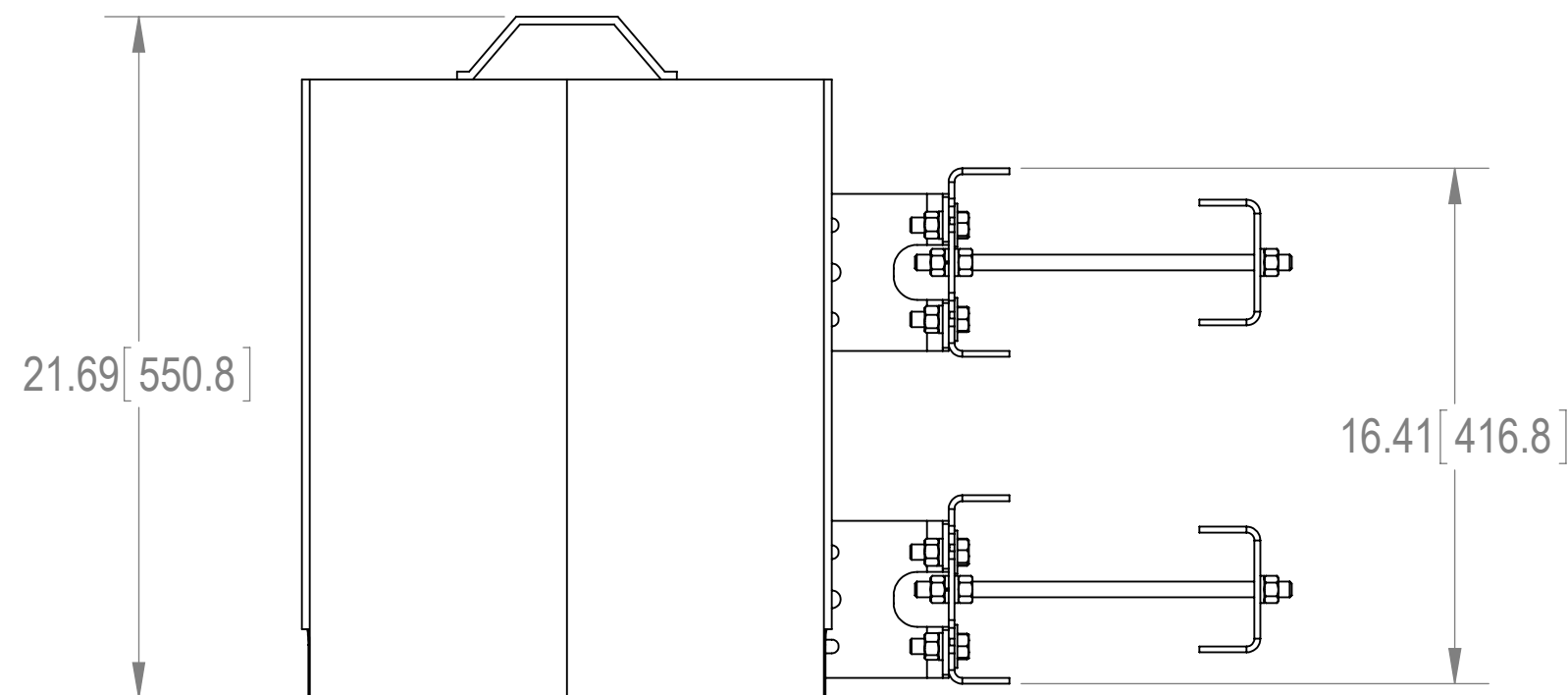
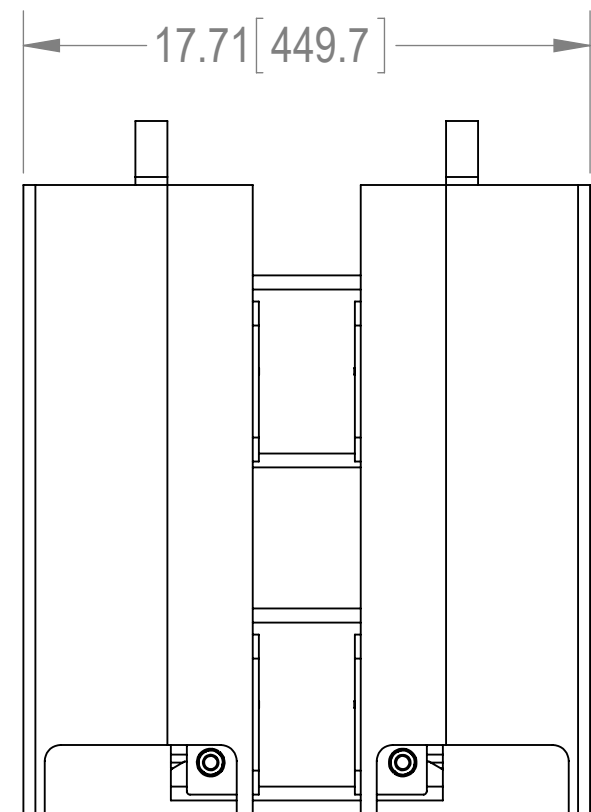
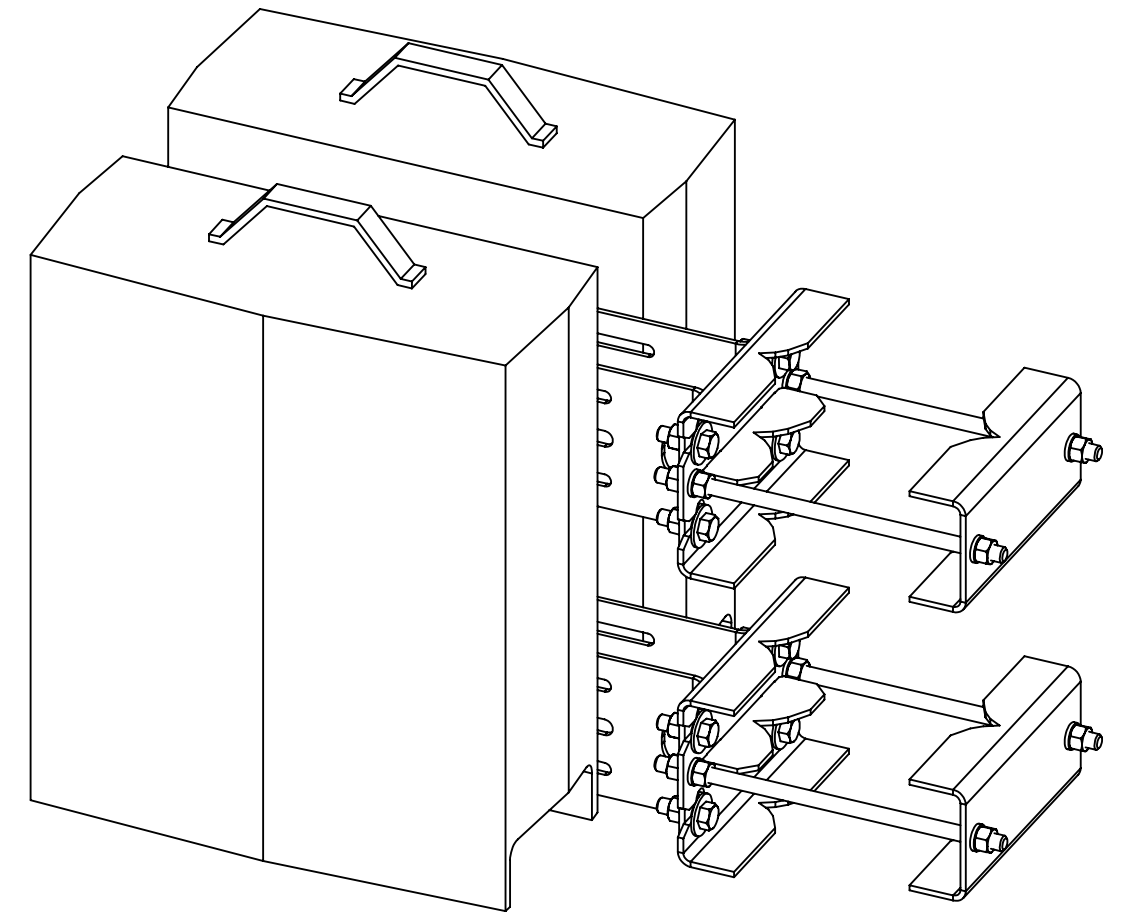
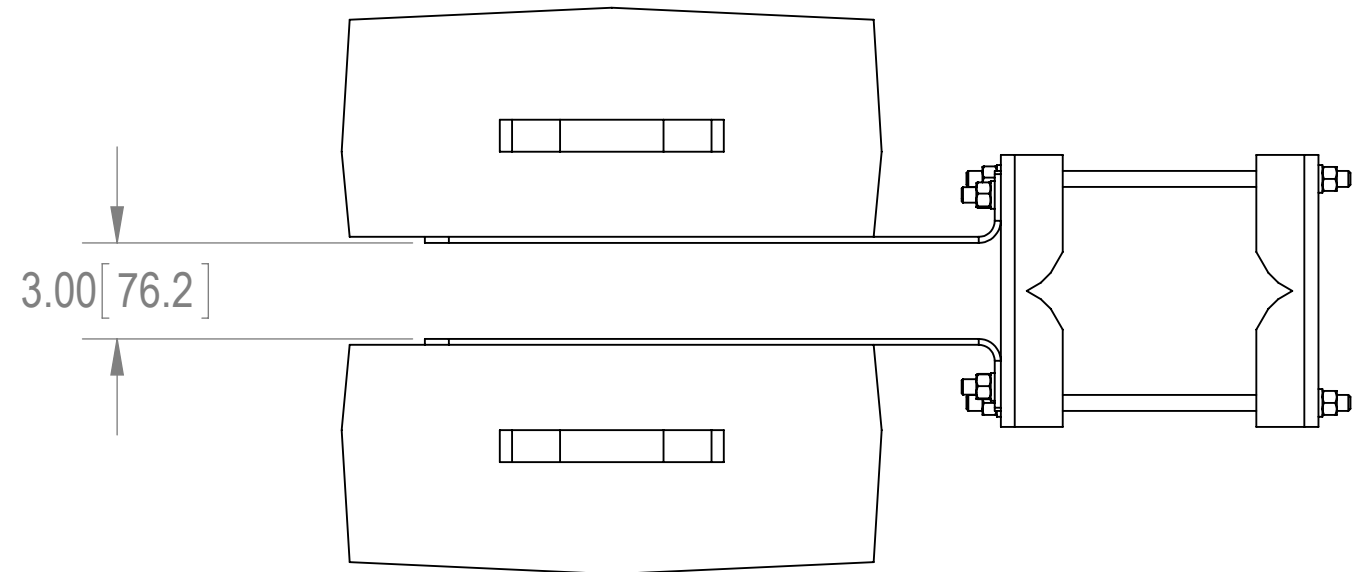

COMMSCOPE, INC. OF NORTH CAROLINA				
TITLE				
FAST ACCESS DUAL RRU MOUNT				
SIZE	SCALE	DOCUMENT NO.		
C	1:6	RR-FA2		
		DRAWING		SHEET
		VERSION	STATUS	REVISION
				A
				4 OF 5

PATENT PENDING

© 2015 CommScope, Inc. Confidential

D

D

C

C

B

B

A

A

4

3

2

1

4

3

2

1

NOTES:

1.0 EXAMPLE INSTALLATION WITH RRU'S AND A2 RADIOS.

D

D

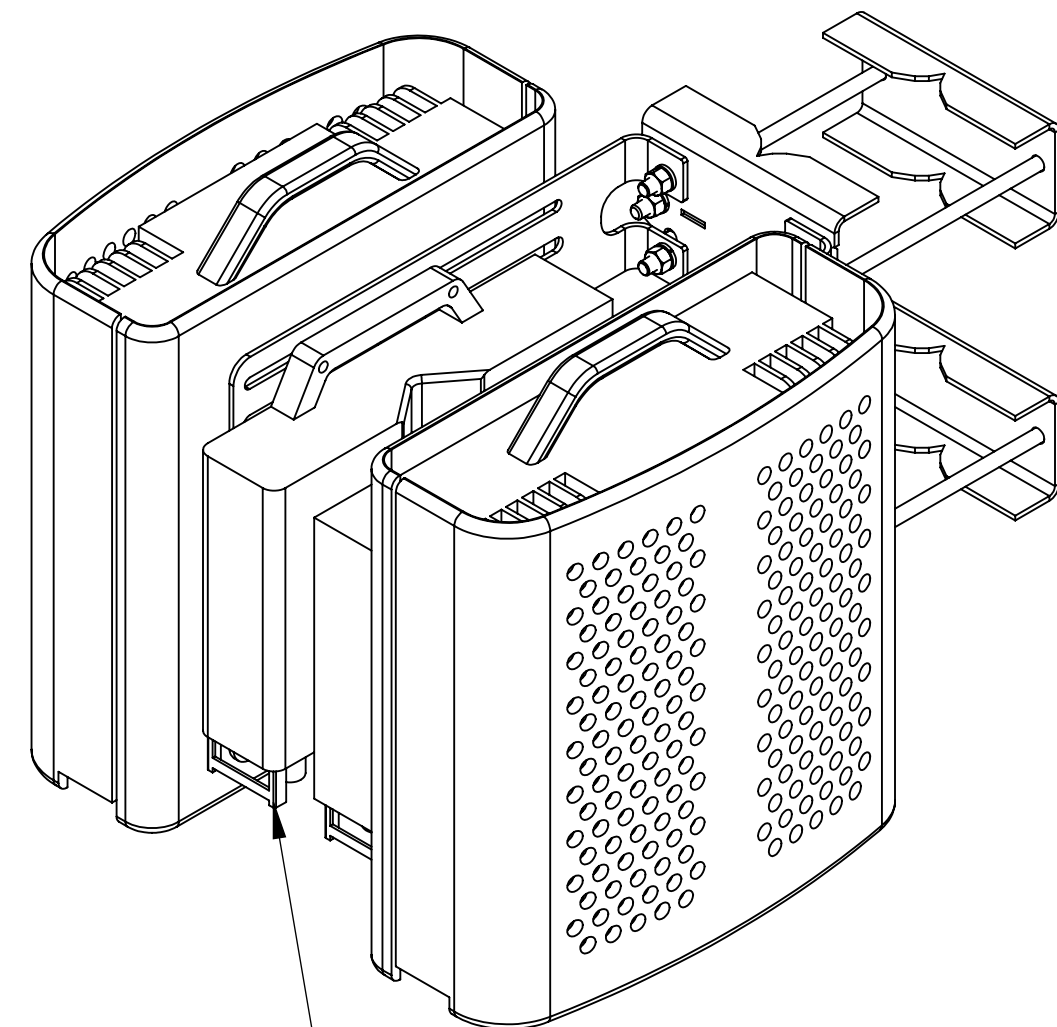

A2 ORDERED SEPARATELY

RRU ORDERED SEPARATELY

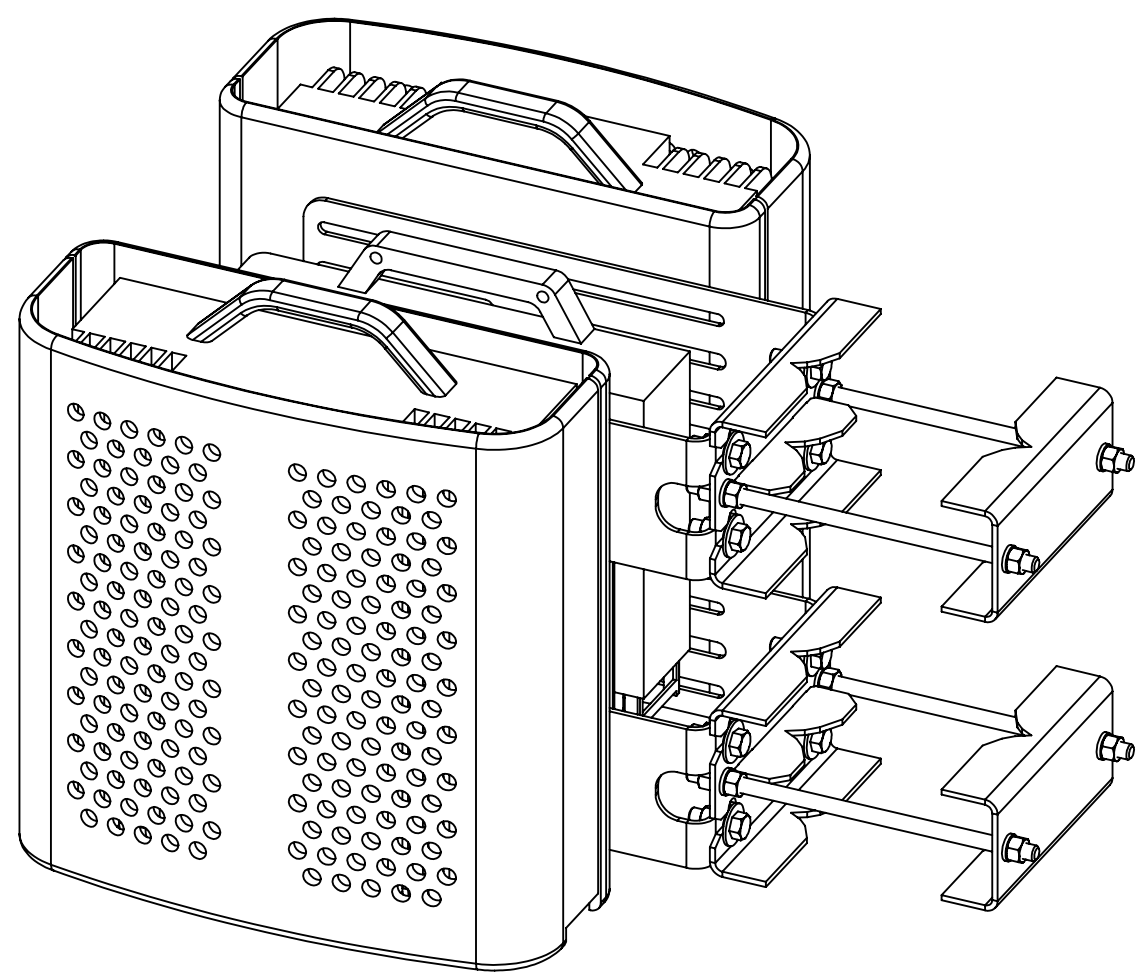
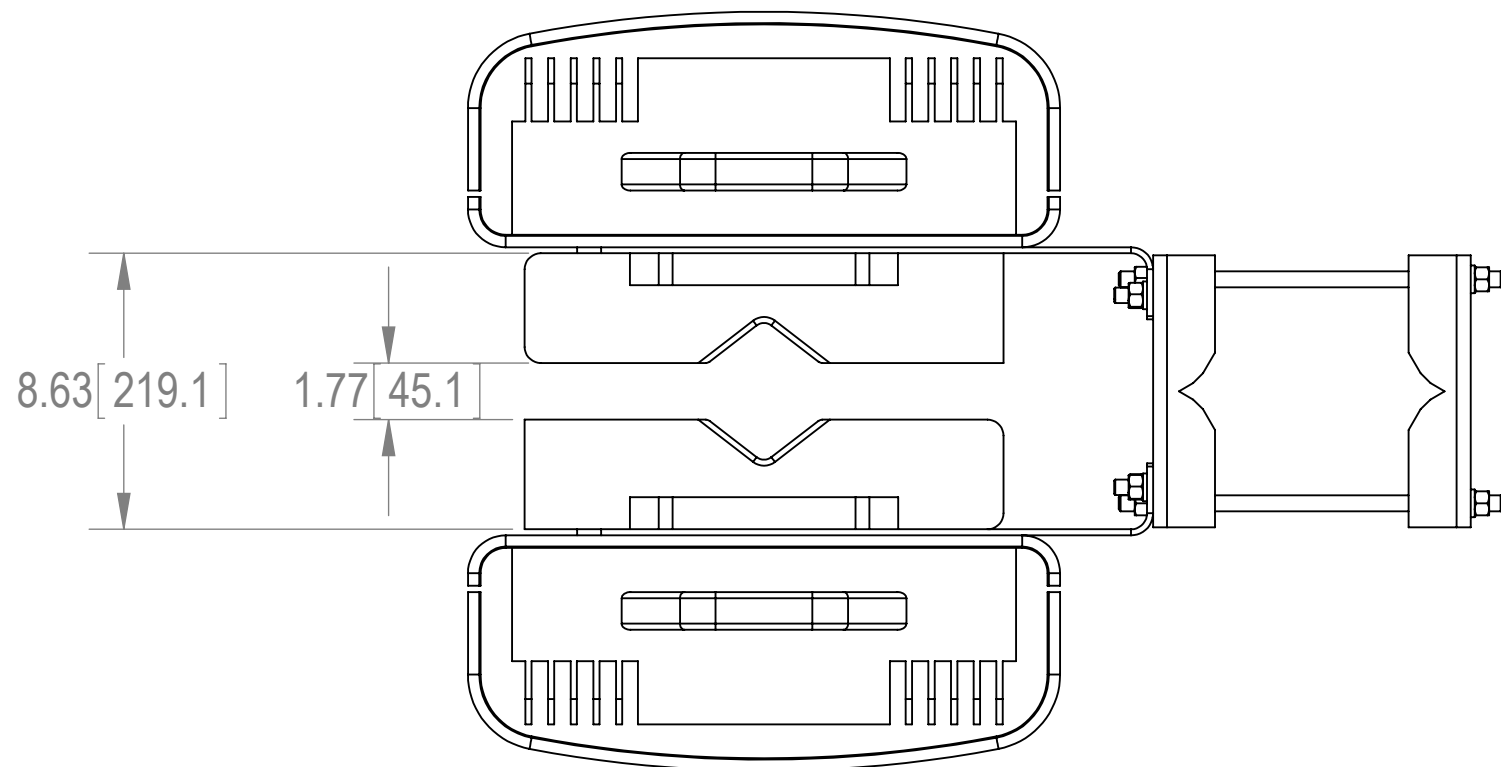

C

C

B

B

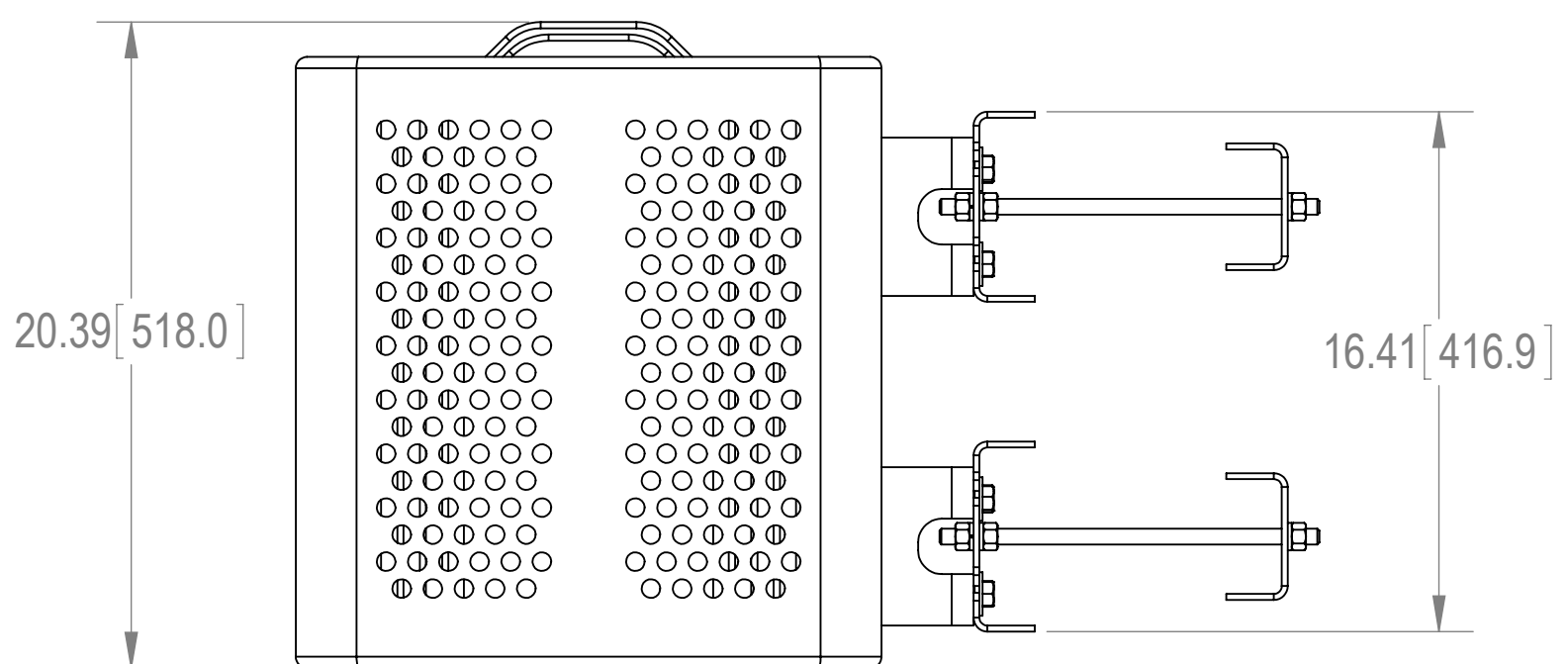
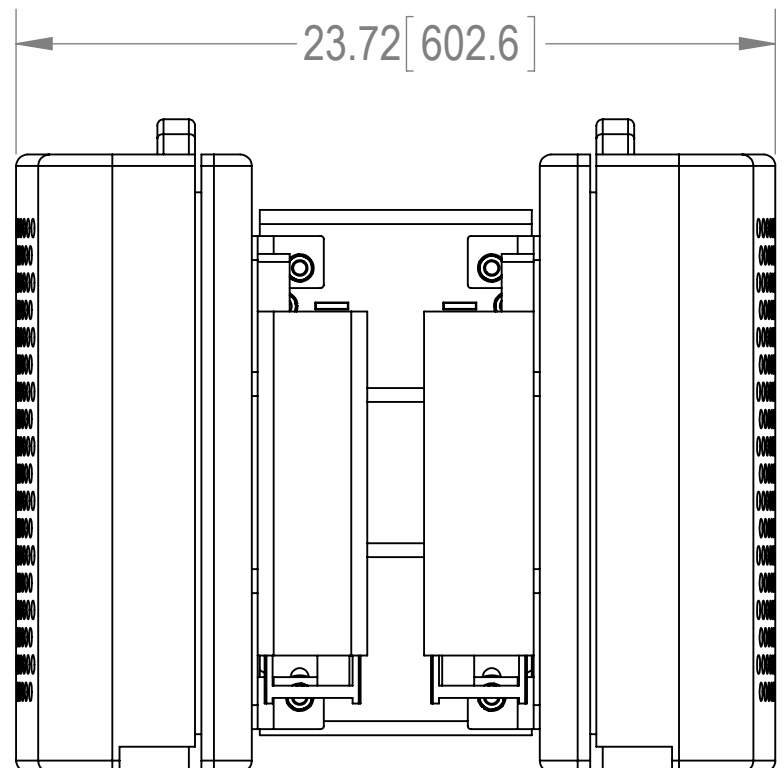

A

A

4

3

2

1

COMMSCOPE, INC. OF NORTH CAROLINA				
TITLE				
FAST ACCESS DUAL RRU MOUNT				
SIZE	SCALE	DOCUMENT NO.		
C	1:6	RR-FA2		
		DRAWING		SHEET
		VERSION	STATUS	REVISION
				A
				5 OF 5

PATENT PENDING

© 2015 CommScope, Inc. Confidential