

A5HF-D

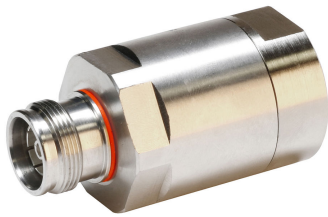

D-Class 4.3-10 Female for 7/8 in AVA5-50 and AVA5-50FX cable

Product Classification

Product Type	Wireless and radiating connector
Product Series	AVA5-50 AVA5RK-50
Ordering Note	CommScope® standard product (Global)

General Specifications

Body Style	Straight
Cable Family	AVA5-50 AVA5-50FX
Inner Contact Attachment Method	Captivated
Inner Contact Plating	Silver
Interface	4.3-10 Female
Mounting Angle	Straight
Outer Contact Plating	Trimetal
Pressurizable	No

Dimensions

Length	64.01 mm 2.52 in
Diameter	34.8 mm 1.37 in
Nominal Size	7/8 in

Outline Drawing

A5HF-D

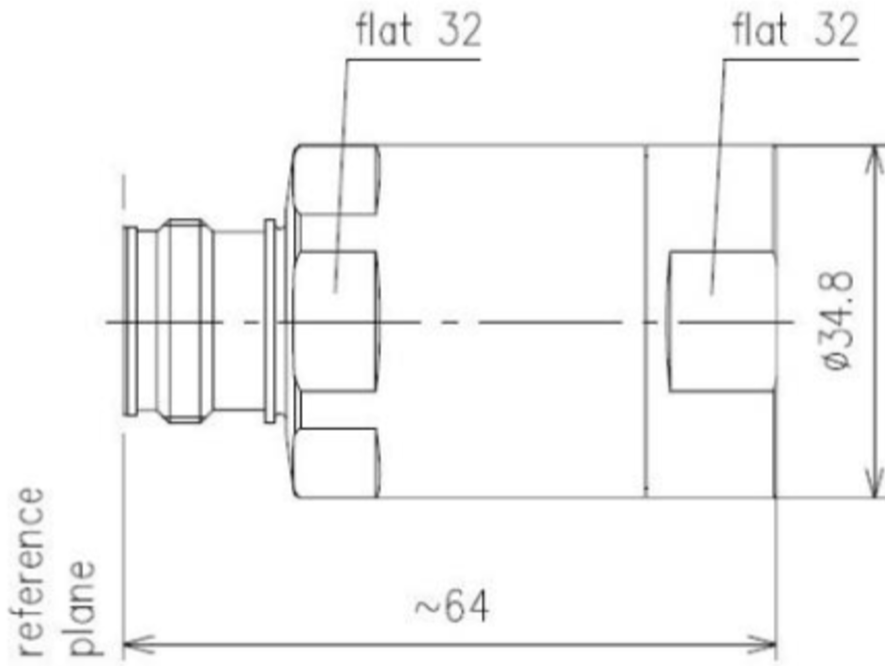

Electrical Specifications

3rd Order IMD at Frequency	-166 -dBc @ 1800 MHz
3rd Order IMD Dynamic Test Method	Two +43 dBm carriers
3rd Order IMD Test Method	Two +43 dBm carriers
Insertion Loss, typical	0.05 dB
Average Power at Frequency	3.0 kW @ 900 MHz
Cable Impedance	50 ohm
Connector Impedance	50 ohm
dc Test Voltage	4000 V
Inner Contact Resistance, maximum	0.4 mOhm
Insulation Resistance, minimum	5000 MOhm
Operating Frequency Band	0 – 5000 MHz

A5HF-D

Outer Contact Resistance, maximum	1.5 mOhm
Peak Power, maximum	40 kW
RF Operating Voltage, maximum (vrms)	1415 V
Shielding Effectiveness	-130 dB

VSWR/Return Loss

Frequency Band	VSWR	Return Loss (dB)
0–1000 MHz	1.03	40
1000–2700 MHz	1.05	34
2700–3800 MHz	1.07	30

Mechanical Specifications

Attachment Durability	25 cycles
Connector Retention Tensile Force	1,334.47 N 300 lbf
Connector Retention Torque	8.14 N-m 72.001 in lb
Insertion Force	200.17 N 45 lbf
Insertion Force Method	IEC 61169-1:15.2.4
Interface Durability	50 cycles
Interface Durability Method	IEC 61169-4:9.5
Mechanical Shock Test Method	IEC 60068-2-27

Environmental Specifications

Operating Temperature	-40 °C to +85 °C (-40 °F to +185 °F)
Storage Temperature	-55 °C to +85 °C (-67 °F to +185 °F)
Attenuation, Ambient Temperature	20 °C 68 °F
Average Power, Ambient Temperature	40 °C 104 °F
Corrosion Test Method	IEC 60068-2-11
Immersion Depth	1 m
Immersion Test Mating	Mated
Immersion Test Method	IEC 60529:2001, IP68
Moisture Resistance Test Method	MIL-STD-202F, Method 106F
Thermal Shock Test Method	MIL-STD-202, Method 107, Test Condition A-1, -55 °C to +85 °C
Vibration Test Method	IEC 60068-2-6

A5HF-D

Water Jetting Test Mating	Mated
Water Jetting Test Method	IEC 60529:2001, IP66

Packaging and Weights

Weight, net	160.5 g 0.354 lb
--------------------	--------------------

Regulatory Compliance/Certifications

Agency	Classification
CHINA-ROHS	Below maximum concentration value
ISO 9001:2015	Designed, manufactured and/or distributed under this quality management system
REACH-SVHC	Compliant as per SVHC revision on www.commscope.com/ProductCompliance
ROHS	Compliant



* Footnotes

Immersion Depth	Immersion at specified depth for 24 hours
Insertion Loss, typical	$0.05\sqrt{\text{freq}}$ (GHz) (not applicable for elliptical waveguide)