

TA-NMNM



Type N Male to Type N Male Low-PIM Adapter

Product Classification

Product Type Adapter

General Specifications

Interface N Male
Interface 2 N Male
Body Style Straight
Mounting Angle Straight

Electrical Specifications

Connector Impedance 50 ohm
Operating Frequency Band 0 – 6000 MHz
3rd Order IMD, typical -163 -dBc @ 1800 MHz
3rd Order IMD Test Method Two +43 dBm carriers
RF Operating Voltage, maximum (vrms) 707.00 V
dc Test Voltage 2500 V
Outer Contact Resistance, maximum 0.25 mOhm
Inner Contact Resistance, maximum 1.00 mOhm
Insulation Resistance, minimum 5000 MOhm
Peak Power, maximum 10.00 kW

Outline Drawing

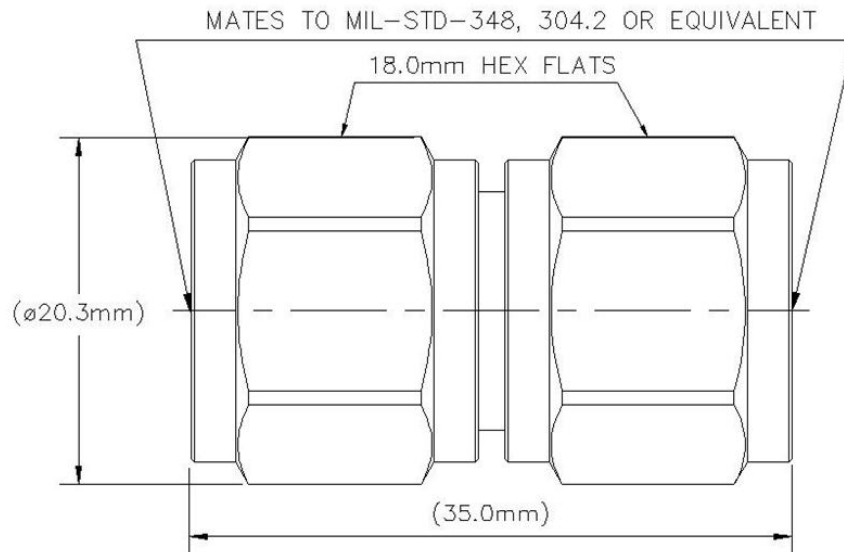

Mechanical Specifications

Coupling Nut Proof Torque	1.70 N-m 1.25 ft lb
Coupling Nut Proof Torque Method	IEC 61169-16:9.3.6
Coupling Nut Retention Force	450.00 N 101.16 lbf
Coupling Nut Retention Force Method	IEC 61169-16:9.3.11
Inner Contact Plating	Silver
Interface Durability	500 cycles
Interface Durability Method	IEC 61169-16:9.5
Outer Contact Plating	Trimetal

Dimensions

Diameter	20.62 mm 0.81 in
Length	35.00 mm 1.38 in
Weight	46.79 g 0.10 lb
Width	20.25 mm 0.80 in

TA-NMNM

Environmental Specifications

Operating Temperature	-55 °C to +85 °C (-67 °F to +185 °F)
Storage Temperature	-65 °C to +125 °C (-85 °F to +257 °F)
Mechanical Shock Test Method	IEC 60068-2-27
Climatic Sequence Test Method	IEC 60068-1
Damp Heat Steady State Test Method	IEC 60068-2-3
Thermal Shock Test Method	IEC 60068-2-14
Vibration Test Method	IEC 60068-2-6
Corrosion Test Method	IEC 60068-2-11

Standard Conditions

Attenuation, Ambient Temperature	20 °C 68 °F
Average Power, Ambient Temperature	40 °C 104 °F
Average Power, Inner Conductor Temperature	100 °C 212 °F

Return Loss/VSWR

Frequency Band	VSWR	Return Loss (dB)
0–3000 MHz	1.02	40.00
3000–6000 MHz	1.04	35.00

Regulatory Compliance/Certifications

Agency

RoHS 2011/65/EU
ISO 9001:2015
China RoHS SJ/T 11364-2014

Classification

Compliant by Exemption
Designed, manufactured and/or distributed under this quality management system
Above Maximum Concentration Value (MCV)

