

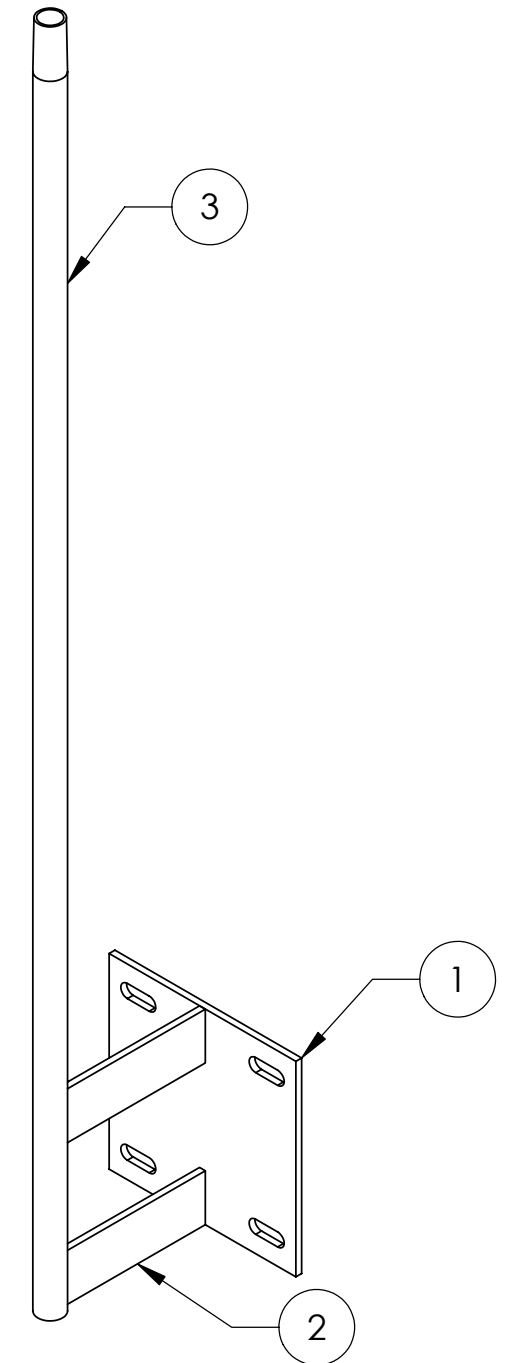

ITEM	PART NO.	DESCRIPTION	QTY.	WEIGHT
1	VCGPSWM.01	MOUNTING PLATE	1	4.29 LBS
2	VCGPSWM.02	SPACER BAR	2	0.85 LBS
3	VCGPSWM.03	MAST	1	4.47 LBS

REVISIONS				
REV.	ZONE	DESCRIPTION	BY	DATE
A		INITIAL RELEASE	ACG	06/04/02

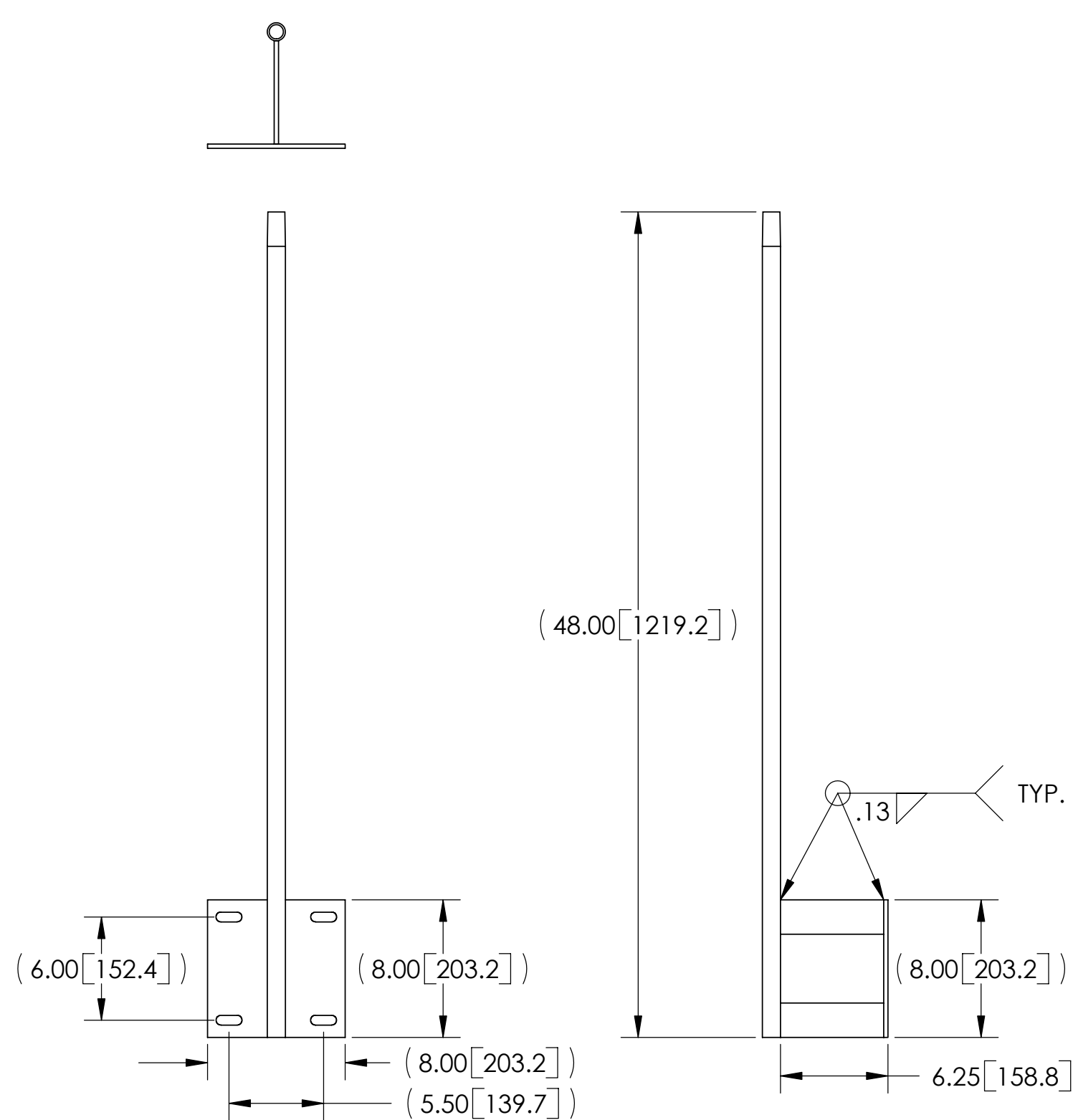

NOTES:

1. ALL METRIC DIMENSIONS ARE IN BRACKETS.
2. STAMP PART IDENTIFICATION NUMBER.
3. WELDING WORKMANSHIP PER AWS D1.1, TABLE 6.1.

<small>These drawings and specifications are the proprietary property of ANDREW CORPORATION and may be used only for the specific purpose authorized in writing by Andrew Corporation.</small> ALL DIMENSIONS ARE IN INCHES U.O.S. TOLERANCES UNLESS OTHERWISE SPECIFIED: .X = ± .06      ANGLES      ±2° .XX = ± .03      FRACTIONS      ±1/32 .XXX = ± .010 REMOVE BURRS AND BREAK EDGES .005 DO NOT SCALE THIS PRINT	DRAWN BY: ACG	SHEET: 1 of 1	PART NUMBER: VC-GPSWM
	CHECKED BY: TP	SCALE: NTS	DESCRIPTION: GPS ANTENNA WALL MOUNT
	DATE: 09/05/06	MATERIAL: A36, A53	DRAWING TYPE: ASSEMBLY DRAWING
	REVISION: A	FINISH: GALV A123	 ORLAND PARK, IL. 60462 U.S.A.
	WEIGHT: 10.45 LBS		