

# CM-30D-B

---

Chain Mount Base Kit, 8 ft chain

## Product Classification

**Product Type** Chain mount kit

## General Specifications

**Pipe, quantity** 0

**Sectors, quantity** 2

## Dimensions

**Height** 152.4 mm | 6 in

**Width** 203.2 mm | 8 in

**Length** 203.2 mm | 8 in

**Pipe Outer Diameter** 60.96 mm | 2.4 in

# CM-30D-B

## Outline Drawing

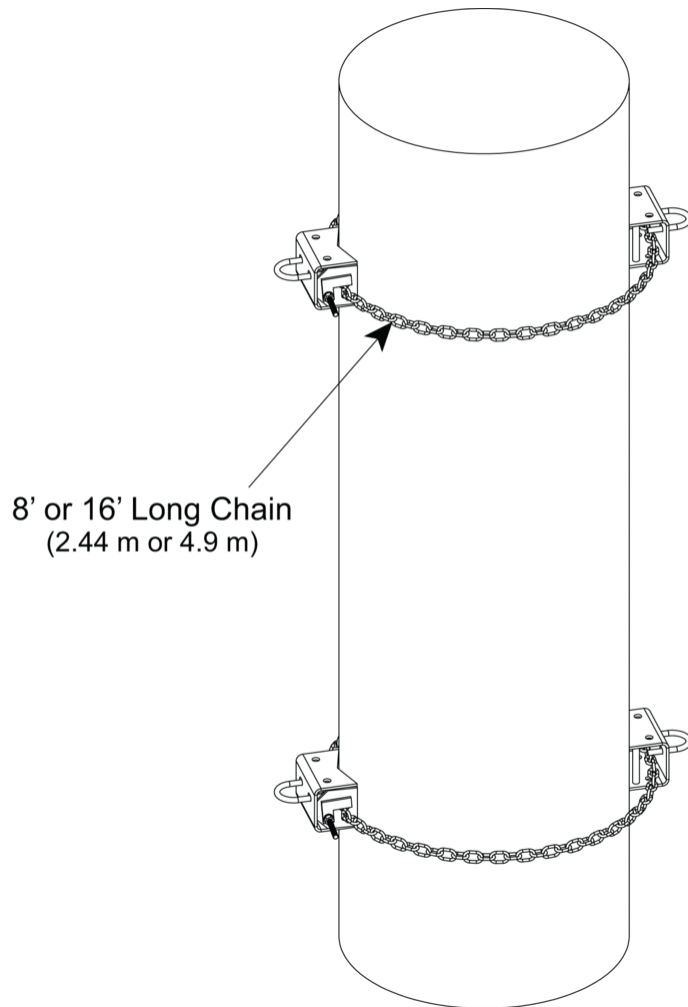

## Mechanical Specifications

|                                |  |
|--------------------------------|--|
| <b>Wind Rating</b>             | 120 mph (BWS) at 100 ft AGL                |
| <b>Wind Rating Criteria</b>    | One 96 in x 10 in panel antenna per sector |
| <b>Wind Rating Test Method</b> | TIA/EIA-222                                |

## Environmental Specifications

|                   |  |
|-------------------|--|
| <b>Man Rating</b> | 250 lb vertical man load at 15 mph (BWS) |
|-------------------|--|

## Packaging and Weights

|                           |   |
|---------------------------|---|
| <b>Packaging quantity</b> | 1 |
|---------------------------|---|

# CM-30D-B

---

**Weight, net** 17.6 kg | 38.801 lb

## Regulatory Compliance/Certifications

**Agency**

ISO 9001:2015



**Classification**

Designed, manufactured and/or distributed under this quality management system

## \* Footnotes

**Man Rating**

BWS—w Base Wind Speed

**Wind Rating**

BWS—w Base Wind Speed; FBC—Florida Building Code