

ITEM	PART NO.	DESCRIPTION	QTY.	WEIGHT
1	CM01	Chain Mount Anchor	2	6.17 LBS
2	CM.03	CHAIN LOCK	2	0.20 LBS
3	CM.04	1/2" X 6" Under Jaw Turnbuckle	2	0.68 LBS
4	GWL-04	1/2" GALV LOCK WASHER	2	0.01 LBS
5	GN-04	1/2" GALV HEX NUT	2	0.02 LBS
6	GUB-4240	1/2" X 2-1/2" X 4" GALV U-BOLT	2	0.72 LBS
7	G-4-XXX	CHAIN (SEE TABLE)	2	
8	MT-XXX	Ø 2-3/8" O.D. PIPE (SEE TABLE)	-	

REVISIONS				
REV.	ZONE	DESCRIPTION	BY	DATE
A		INITIAL RELEASE	AW	12/04/04
B		UPDATE BOM	ACG	03/12/09

PART NUMBER	WEIGHT	PIPE MOUNT	QTY	CHAIN	CHAIN LENGTH
CM-30S-B	26.76	NONE	0	G4-0-96	8ft
CM-30S-72	47.76	MT-651	1	G4-0-96	8ft
CM-30S-96	60.26	MT-651-96	1	G4-0-96	8ft
CM-60S-B	38.76	NONE	0	G4-0-192	16ft
CM-60S-72	59.76	MT-651	1	G4-0-192	16ft
CM-60S-96	72.26	MT-651-96	1	G4-0-192	16ft

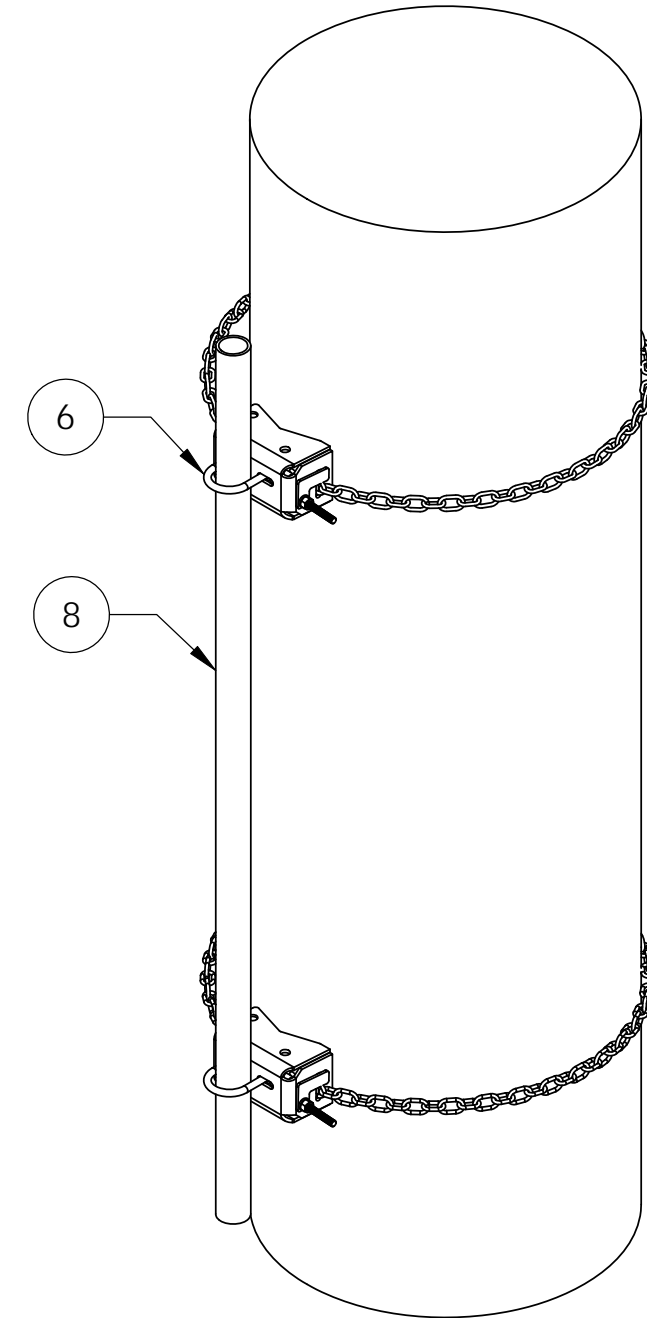
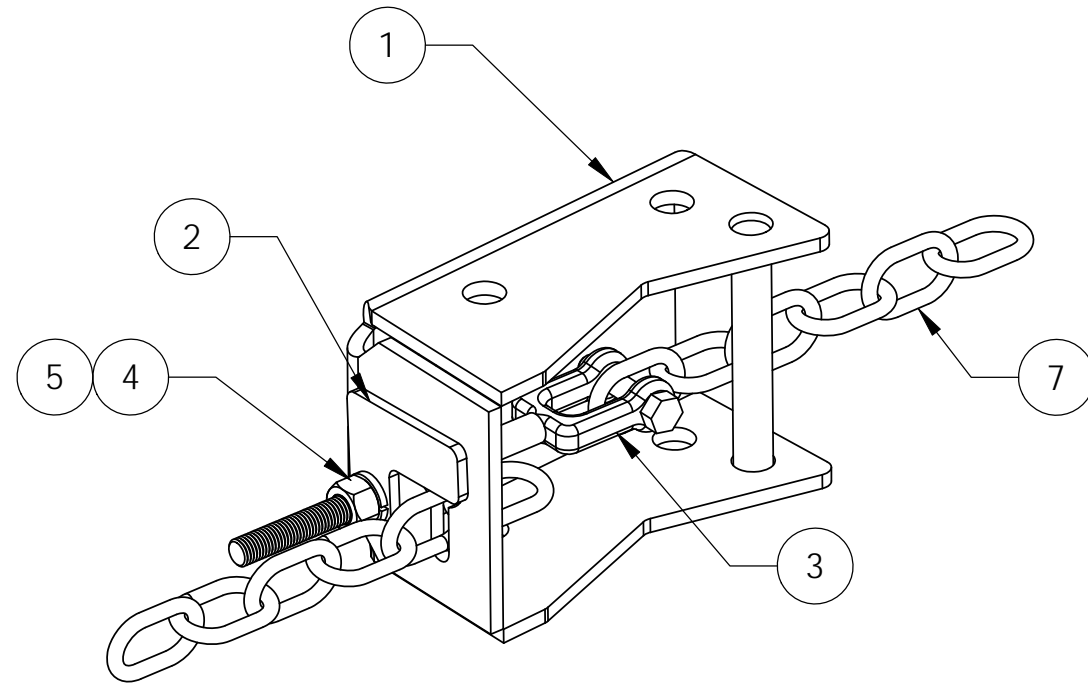

NOTES:

- ATTACH THE PIPES OR PIPE MOUNTS TO THE BRACKETS PRIOR TO ADDING THE JAW-BOLT/CHAIN ASSEMBLY

<small>These drawings and specifications are the proprietary property of ANDREW CORPORATION and may be used only for the specific purpose authorized in writing by Andrew Corporation.</small> ALL DIMENSIONS ARE IN INCHES U.O.S. TOLERANCES UNLESS OTHERWISE SPECIFIED: .X = .12 ANGLES 2' .XX = .06 FRACTIONS 1/32 .XXX = .003 REMOVE BURRS AND BREAK EDGES .005 DO NOT SCALE THIS PRINT	DRAWN BY: AW	SHEET: 1 of 1	PART NUMBER: CM-S SERIES
	CHECKED BY: TP	SCALE: NTS	DESCRIPTION: SINGLE CHAIN MOUNT
	DATE: 12/14/04	MATERIAL: A36, A53	DRAWING TYPE: ASSEMBLY DRAWING
	REVISION: B	FINISH: GALV A123	 ORLAND PARK, IL. 60462 U.S.A.
	WEIGHT: SEE TABLE		