

CM-SH60

Heavy Duty Stiff Arm Mount, two 16 ft chains

Product Classification

Product Type Stiff arm mount

General Specifications

Chains, quantity 2

Dimensions

Height	152.4 mm 6 in
Width	203.2 mm 8 in
Chain Length	4,902.2 mm 193 in
Length	1,168.4 mm 46 in
Mounting Diameter, maximum	1524 mm 60 in
Mounting Diameter, minimum	203.2 mm 8 in
Stand-off Distance	1,219.2 mm 48 in
Mounting Circumference, maximum	4,775.2 mm 188 in
Mounting Circumference, minimum	635 mm 25 in

CM-SH60

Outline Drawing

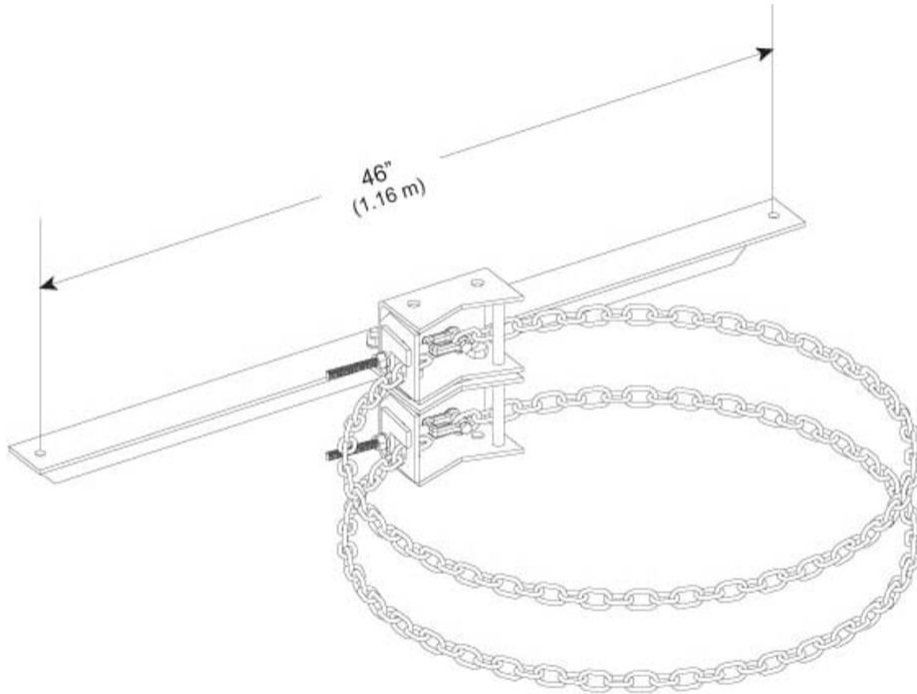

Material Specifications

Material Type Hot dip galvanized steel

Packaging and Weights

Included Chains | Stiff arm attachment

Packaging quantity 1

Weight, net 28.1 kg | 61.95 lb

Regulatory Compliance/Certifications

Agency	Classification
--------	----------------

CM-SH60

ISO 9001:2015

Designed, manufactured and/or distributed under this quality management system

