

## Multi-Sector Cluster Mount

### Product Classification

**Product Type** Tripod mount component

### General Specifications

**Mounting** Round member, 101.6–152.4 mm (4–6 in) OD

### Dimensions

**Height** 101.6 mm | 4 in

**Width** 330.2 mm | 13 in

**Length** 0.335 m | 1.1 ft

**Pipe Outer Diameter** 60.96 mm | 2.4 in

**Stand-off Distance** 114.3 mm | 4.5 in

# TP-MSC

## Outline Drawing

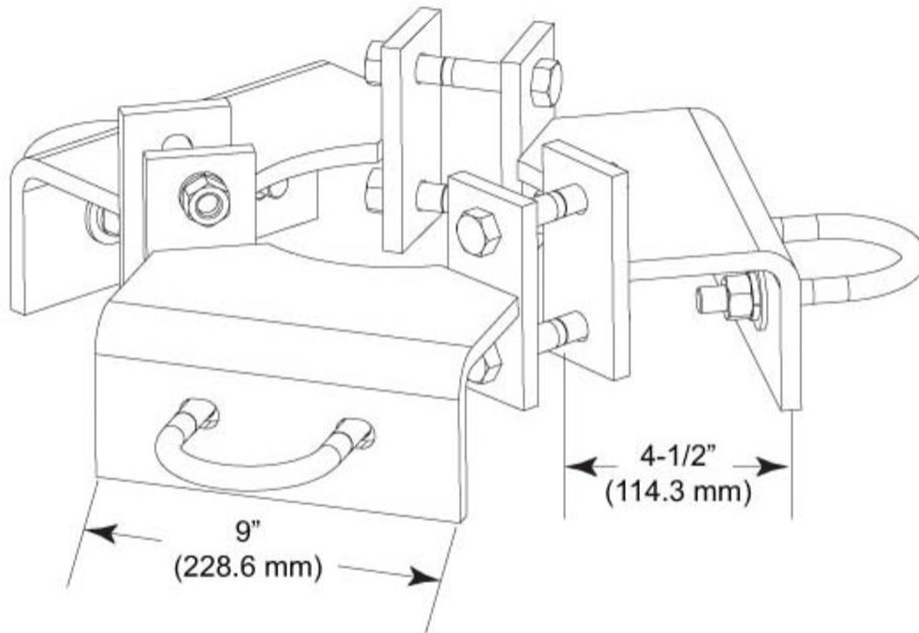

## Material Specifications

**Material Type** Hot dip galvanized steel

## Mechanical Specifications

**Wind Rating** For Specifications, please contact [steelproducts@commscope.com](mailto:steelproducts@commscope.com) or call 800-255-1479

## Packaging and Weights

**Included** Brackets | U-bolts

**Packaging quantity** 1

**Weight, net** 20.3 kg | 44.754 lb

# TP-MSC

---

## Regulatory Compliance/Certifications

**Agency**

ISO 9001:2015

**Classification**

Designed, manufactured and/or distributed under this quality management system

### \* Footnotes

**Wind Rating**

BWS—w Base Wind Speed; FBC—Florida Building Code