

# AL7E158-PS

---

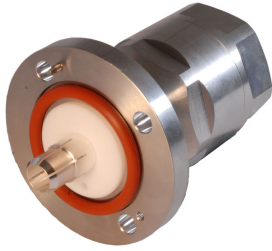

1-5/8 in EIA Flange for 1-5/8 in AVA7-50, AL7-50 and LDF7-50 cable

## Product Classification

<b>Product Type</b>	Wireless and radiating connector
<b>Product Brand</b>	HELIAX®

## General Specifications

<b>Body Style</b>	Straight
<b>Cable Family</b>	AL7-50   AVA7-50
<b>Inner Contact Attachment Method</b>	Thread-in stub
<b>Inner Contact Plating</b>	Silver
<b>Interface</b>	1-5/8 in EIA Flange
<b>Mounting Angle</b>	Straight
<b>Outer Contact Attachment Method</b>	Self-flare
<b>Outer Contact Plating</b>	Trimetal
<b>Pressurizable</b>	No

## Dimensions

<b>Length</b>	106.68 mm   4.2 in
<b>Diameter</b>	89.15 mm   3.51 in
<b>Nominal Size</b>	1-5/8 in

## Outline Drawing

# AL7E158-PS

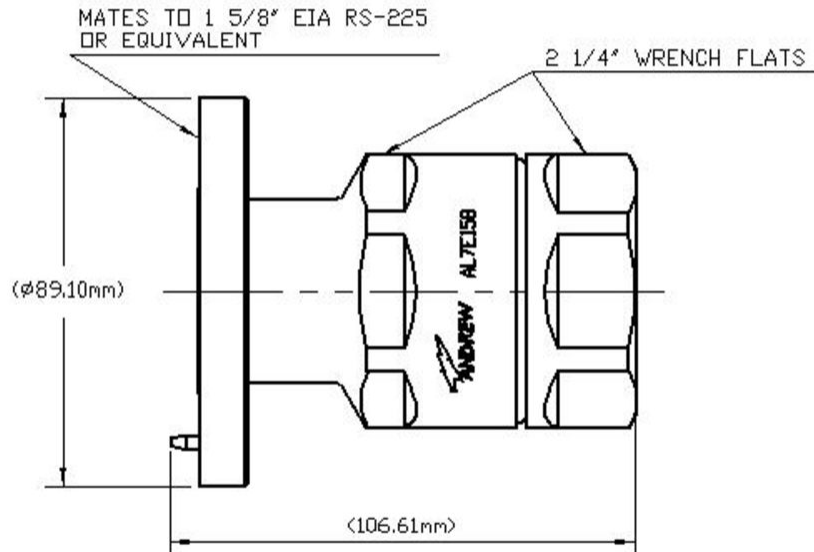

## Electrical Specifications

<b>Insertion Loss, typical</b>	0.05 dB
<b>Average Power at Frequency</b>	3.4 kW @ 900 MHz
<b>Cable Impedance</b>	50 ohm
<b>Connector Impedance</b>	50 ohm
<b>dc Test Voltage</b>	15000 V
<b>Inner Contact Resistance, maximum</b>	1.5 mOhm
<b>Insulation Resistance, minimum</b>	5000 MOhm
<b>Operating Frequency Band</b>	0 – 2500 MHz
<b>Outer Contact Resistance, maximum</b>	1.5 mOhm
<b>Peak Power, maximum</b>	90 kW
<b>RF Operating Voltage, maximum (vrms)</b>	2120 V

# AL7E158-PS

---

**Shielding Effectiveness** -110 dB

## VSWR/Return Loss

Frequency Band	VSWR	Return Loss (dB)
45–1000 MHz	1.04	35
1010–2200 MHz	1.04	35
2210–2500 MHz	1.07	30

## Mechanical Specifications

<b>Attachment Durability</b>	25 cycles
<b>Connector Retention Tensile Force</b>	2,224.11 N   500 lbf
<b>Connector Retention Torque</b>	13.56 N-m   119.998 in lb
<b>Interface Durability</b>	50 cycles
<b>Mechanical Shock Test Method</b>	MIL-STD-202, Method 213, Test Condition I

## Environmental Specifications

<b>Operating Temperature</b>	-55 °C to +85 °C (-67 °F to +185 °F)
<b>Storage Temperature</b>	-55 °C to +85 °C (-67 °F to +185 °F)
<b>Attenuation, Ambient Temperature</b>	20 °C   68 °F
<b>Average Power, Ambient Temperature</b>	40 °C   104 °F
<b>Corrosion Test Method</b>	MIL-STD-1344A, Method 1001.1, Test Condition A
<b>Immersion Depth</b>	1 m
<b>Immersion Test Mating</b>	Mated
<b>Immersion Test Method</b>	IEC 60529:2001, IP68
<b>Moisture Resistance Test Method</b>	MIL-STD-202, Method 106
<b>Thermal Shock Test Method</b>	MIL-STD-202F, Method 107G, Test Condition A-1, Low Temperature -55 °C
<b>Vibration Test Method</b>	MIL-STD-202, Method 204, Test Condition B
<b>Water Jetting Test Mating</b>	Mated
<b>Water Jetting Test Method</b>	IEC 60529:2001, IP66

## Packaging and Weights

**Weight, net** 1,097.4 g | 2.419 lb

## Regulatory Compliance/Certifications

# AL7E158-PS

---

**Agency**

ISO 9001:2015

**Classification**

Designed, manufactured and/or distributed under this quality management system

**\* Footnotes****Immersion Depth**

Immersion at specified depth for 24 hours

**Insertion Loss, typical**

$0.05\sqrt{\text{freq}}$  (GHz) (not applicable for elliptical waveguide)