

# EQ-P-AL

---

## Equipment Platform Adjustable Leg

### Product Classification

**Product Type**            Equipment platform system

### Dimensions

**Height**                    685.8 mm | 27 in

**Width**                     406.4 mm | 16 in

**Length**                    406.4 mm | 16 in

# EQ-P-AL

## Outline Drawing

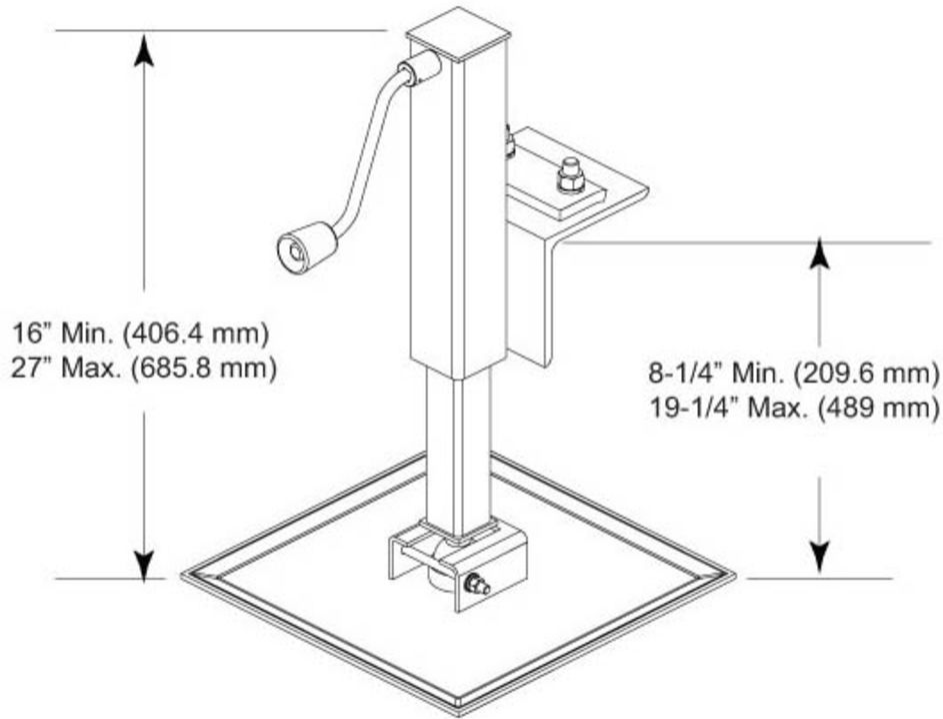

## Material Specifications

**Material Type** Hot dip galvanized steel

## Packaging and Weights

**Included** Legs  
**Packaging quantity** 1  
**Weight, net** 20.4 kg | 44.974 lb

## Regulatory Compliance/Certifications

**Agency** **Classification**

# EQ-P-AL

---

ISO 9001:2015

Designed, manufactured and/or distributed under this quality management system

