

# VHLPX4-7W-4WH/E

---



1.2 m | 4 ft ValuLine® High Performance Low Profile Antenna, dual-polarized, 7.125–8.500 GHz, PDR84, white antenna, flexible woven polymer gray radome without flash, standard pack—one-piece reflector

## Product Classification

<b>Product Type</b>	Microwave antenna
<b>Product Brand</b>	ValuLine®

## General Specifications

<b>Antenna Type</b>	VHLPX - ValuLine® High Performance Low Profile Antenna, dual-polarized
<b>Polarization</b>	Dual
<b>Antenna Input</b>	PDR84
<b>Antenna Color</b>	White
<b>Reflector Construction</b>	One-piece reflector
<b>Radome Color</b>	Gray
<b>Radome Material</b>	Flexible woven polymer
<b>Flash Included</b>	No
<b>Side Struts, Included</b>	1 inboard
<b>Side Struts, Optional</b>	1 inboard

## Dimensions

<b>Diameter, nominal</b>	1.2 m   4 ft
--------------------------	--------------

# VHLPX4-7W-4WH/E

## Antenna Dimensions and Mounting Information

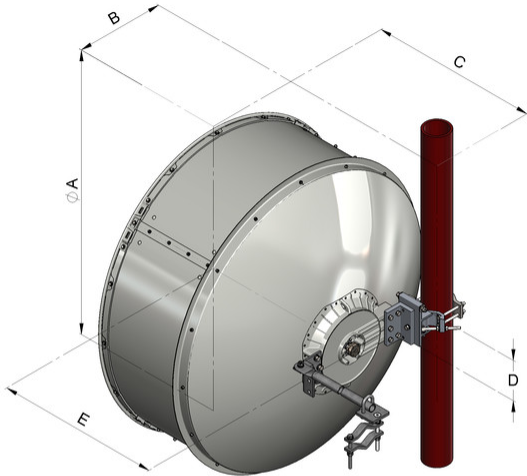

Dimensions in inches (mm)					
Antenna size, ft (m)	A	B	C	D	E
4 (1.2)	50.8 (1291)	16 (407)	30.2 (767)	7.2 (183)	29.5 (748)

## Electrical Specifications

<b>Operating Frequency Band</b>	7.125 – 8.500 GHz
<b>Gain, Low Band</b>	36.9 dBi
<b>Gain, Mid Band</b>	37.4 dBi
<b>Gain, Top Band</b>	37.7 dBi
<b>Boresite Cross Polarization Discrimination (XPD)</b>	30 dB
<b>Front-to-Back Ratio</b>	63 dB
<b>Beamwidth, Horizontal</b>	2.2 °
<b>Beamwidth, Vertical</b>	2.2 °
<b>Return Loss</b>	17.7 dB

# VHLPX4-7W-4WH/E

---

<b>VSWR</b>	1.3
<b>Radiation Pattern Envelope Reference (RPE)</b>	7080E
<b>Electrical Compliance</b>	Brazil Anatel Class 2   ETSI 302 217 Class 3

## Mechanical Specifications

<b>Compatible Mounting Pipe Diameter</b>	115 mm   4.5 in
<b>Fine Azimuth Adjustment Range</b>	±15°
<b>Fine Elevation Adjustment Range</b>	±15°
<b>Wind Speed, operational</b>	200 km/h   124.274 mph
<b>Wind Speed, survival</b>	250 km/h   155.343 mph

## Wind Forces at Wind Velocity Survival Rating

<b>Axial Force (FA)</b>	5326 N   1,197.333 lbf
<b>Side Force (FS)</b>	2638 N   593.046 lbf
<b>Twisting Moment (MT)</b>	2162 N-m   19,135.312 in lb
<b>Force on Inboard Strut Side</b>	2862 N   643.403 lbf
<b>Zcg without Ice</b>	43 mm   1.693 in
<b>Zcg with 1/2 in (12 mm) Radial Ice</b>	284 mm   11.181 in
<b>Weight with 1/2 in (12 mm) Radial Ice</b>	74 kg   163.142 lb

# VHLPX4-7W-4WH/E

## Wind Forces at Wind Velocity Survival Rating Image

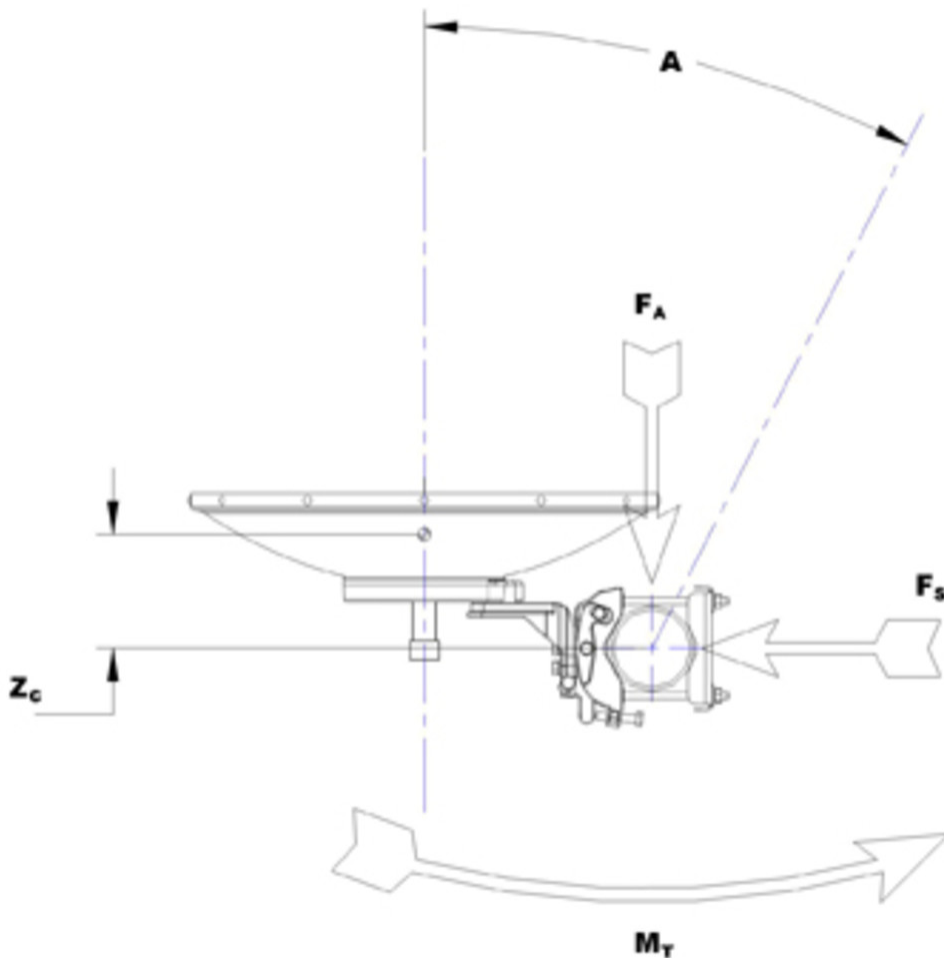

## Packaging and Weights

<b>Height, packed</b>	1520 mm   59.843 in
<b>Width, packed</b>	380 mm   14.961 in
<b>Length, packed</b>	1360 mm   53.543 in
<b>Packaging Type</b>	Standard pack
<b>Volume</b>	0.8 m <sup>3</sup>   28.252 ft <sup>3</sup>
<b>Weight, gross</b>	59 kg   130.073 lb
<b>Weight, net</b>	32 kg   70.548 lb

## Regulatory Compliance/Certifications

# VHLPX4-7W-4WH/E

## Agency

CHINA-ROHS  
ISO 9001:2015  
REACH-SVHC  
ROHS

## Classification

Below maximum concentration value  
Designed, manufactured and/or distributed under this quality management system  
Compliant as per SVHC revision on [www.commscope.com/ProductCompliance](http://www.commscope.com/ProductCompliance)  
Compliant



## \* Footnotes

### Axial Force (FA)

Maximum forces exerted on a supporting structure as a result of wind from the most critical direction for this parameter. The individual maximums specified may not occur simultaneously. All forces are referenced to the mounting pipe.

### Boresite Cross Polarization Discrimination (XPD)

The difference between the peak of the co-polarized main beam and the maximum cross-polarized signal over an angle twice the 3 dB beamwidth of the co-polarized main beam.

### Front-to-Back Ratio

Denotes highest radiation relative to the main beam, at  $180^\circ \pm 40^\circ$ , across the band. Production antennas do not exceed rated values by more than 2 dB unless stated otherwise.

### Gain, Mid Band

For a given frequency band, gain is primarily a function of antenna size. The gain of Andrew antennas is determined by either gain by comparison or by computer integration of the measured antenna patterns.

### Operating Frequency Band

Bands correspond with CCIR recommendations or common allocations used throughout the world. Other ranges can be accommodated on special order.

### Packaging Type

Andrew standard packing is suitable for export. Antennas are shipped as standard in totally recyclable cardboard or wire-bound crates (dependent on product). For your convenience, Andrew offers heavy duty export packing options.

### Radiation Pattern Envelope Reference (RPE)

Radiation patterns define an antenna's ability to discriminate against unwanted signals. Under still dry conditions, production antennas will not have any peak exceeding the current RPE by more than 3dB, maintaining an angular accuracy of  $\pm 1^\circ$  throughout

### Return Loss

The figure that indicates the proportion of radio waves incident upon the antenna that are rejected as a ratio of those that are accepted.

### Side Force (FS)

Maximum side force exerted on the mounting pipe as a result of wind from the most critical direction for this parameter. The individual maximums specified may not occur simultaneously. All forces are referenced to the mounting pipe.

# VHLPX4-7W-4WH/E

---

**Twisting Moment (MT)**

Maximum forces exerted on a supporting structure as a result of wind from the most critical direction for this parameter. The individual maximums specified may not occur simultaneously. All forces are referenced to the mounting pipe.

**VSWR**

Maximum; is the guaranteed Peak Voltage-Standing-Wave-Ratio within the operating band.

**Wind Speed, operational**

For VHLP(X), SHP(X), HX and USX antennas, the wind speed where the maximum antenna deflection is 0.3 x the 3 dB beam width of the antenna. For other antennas, it is defined as a deflection is equal to or less than 0.1 degrees.

**Wind Speed, survival**

The maximum wind speed the antenna, including mounts and radomes, where applicable, will withstand without permanent deformation. Realignment may be required. This wind speed is applicable to antenna with the specified amount of radial ice.